

01/16-ST02 part 2	version EN07
TSI-TAF	origin EN
23.11.2004	Status NA

Directive 2001/16 - Interoperability of the trans-European conventional rail system

Draft Technical Specification for Interoperability

"Telematic Applications for Freight Services" Sub-System

CONTENTS:

1.	INTRODUCTION	5
1.1.	Technical scope	5
1.2.	Geographical Scope.....	6
1.3.	Content of this TSI	6
2.	DEFINITION OF SUBSYSTEM/SCOPE	7
2.1.	Function within the scope of the TSI	7
2.2.	Functions outside the scope of the TSI.....	7
2.3.	Overview of the subsystem description.....	8
2.3.1.	Involved Entities.....	8
2.3.2.	Considered Processes	10
2.3.3.	General remarks.....	12
3.	ESSENTIAL REQUIREMENTS	15
3.1.	Compliance with the essential requirements	15
3.2.	Essential requirements aspects	15
3.3.	Aspects relating to general requirements	15
3.3.1.	Safety	15
3.3.2.	Reliability and availability	16
3.3.3.	Health.....	16
3.3.4.	Environmental protection	17
3.3.5.	Technical compatibility	17
3.4.	Aspects relating specifically to the Telematic Applications Subsystem for Freight.....	18
3.4.1.	Technical compatibility	18
3.4.2.	Reliability and availability	18
3.4.3.	Health.....	18
3.4.4.	Safety	19
4.	CHARACTERISATION OF THE SUBSYSTEM.....	20
4.1.	Introduction	20
4.2.	Functional and technical specifications of the subsystem.....	20
4.2.1.	Consignment Note data	22
4.2.2.	Path Request	24
4.2.3.	Train Preparation	33
4.2.4.	Train Running Forecast	38
4.2.5.	Service Disruption Information	42

4.2.6.	Train Location	43
4.2.7.	Shipment ETI / ETA.....	46
4.2.8.	Wagon Movement	50
4.2.9.	Interchange Reporting	54
4.2.10.	Data Exchange for Quality Improvement.....	56
4.2.11.	The Main Reference Data.....	59
4.2.12.	Various Reference Files and Databases	62
4.2.13.	Electronic Transmission of Documents.....	66
4.2.14.	Networking & Communication	67
4.3.	Functional and technical specifications of the interfaces.....	71
4.3.1.	Interfaces with the TSI Infrastructure.....	71
4.3.2.	Interfaces with the TSI Control/Command and Signalling	71
4.3.3.	Interfaces with the rolling stock subsystem.....	71
4.3.4.	Interfaces with the TSI operation and traffic management	71
4.4.	Operating rules	72
4.4.1.	Data quality.....	72
4.4.2.	Operating the central repository	74
4.5.	Maintenance rules.....	74
4.6.	Professional qualifications.....	74
4.7.	Health and safety conditions	75
4.8.	Infrastructure and Rolling stock registers.....	75
5.	INTEROPERABILITY CONSTITUENTS	76
5.1.	Definition.....	76
5.2.	List of Constituents.....	76
5.3.	Constituents' Performances and Specifications	76
6.	ASSESSMENT OF CONFORMITY AND/OR SUITABILITY FOR USE OF THE CONSTITUENTS AND VERIFICATION OF THE SUBSYSTEM.....	77
6.1.	Interoperability Constituents	77
6.1.1.	Assessment Procedures.....	77
6.1.2.	Module.....	77
6.2.	Subsystem Telematic Applications for Freight	77
7.	IMPLEMENTATION	79
7.1.	Modalities of Application of this TSI.....	79
7.1.1.	Introduction	79
7.1.2.	Strategic European Deployment Plan (SEDP)	79

7.1.3. Modalities for Implementation	81
7.2. Migration Strategy.....	82
7.3. Management of Change.....	87
7.3.1. Introduction	87
7.3.2. Baselining.....	88
7.3.3. Baseline release	89
7.3.4. Deployment of new baselines.....	90
7.3.5. Change Management Process – the requirements	90
7.3.6. Configuration Management Plan – the requirements.....	91
7.4. Specific cases.....	92
7.4.1. Introduction	92
7.4.2. List of specific cases.....	92
ANNEX A: LIST OF ACCOMPANYING DOCUMENTS	94
ANNEX B: GLOSSARY	95

TABLES:

**FEHLER! ES KONNTEN KEINE EINTRÄGE FÜR EIN
ABBILDUNGSVERZEICHNIS GEFUNDEN WERDEN.**

Trans-European Conventional Rail System

Technical Specification for Interoperability Subsystem Telematic Applications for Freight

1. INTRODUCTION

1.1. Technical scope

This TSI concerns the Telematic Applications subsystem for freight services shown in the list in point 1(b) of Annex II to Directive 2001/16/EC.

The commercial operation of trains, wagons and Intermodal units throughout the Trans-European rail network requires efficient interchange of information between the different Infrastructure Managers, Railway Undertakings and other service providers. Performance levels, safety, quality of service and cost depend upon such compatibility and interchange as does, in particular, the interoperability of the Trans-European conventional rail system.

The technical specification for interoperability also has an impact on the conditions of use of rail transport by users. In this respect the term users is understood to mean not only infrastructure managers or railway undertakings but also all other service providers such as wagon companies, Intermodal operators and even customers.

Last but not least, the benefit of interoperability of the conventional rail system was taken into account to bring about the conditions for greater interoperability between modes of transport, in particular between conventional rail transport and combined rail transport.

The purpose of this TSI is to ensure also that efficient interchange of information is at all times best adapted, with regard to quality and quantity, to changing requirements so that the transport process may remain as economically viable as possible and that freight transport on rail maintains its hold on the market against the intense competition it has to face.

All this means the building or upgrading of the Trans-European Conventional Rail System for conventional rail transport and Intermodal transport. The need for such an upgrade of the rail part of the transport system can also be seen by considering the critical points (interfaces between the various partners involved) in freight transport on road compared with the critical points of freight transport on rail for one simplified scenario as shown in Annex A index 5 chapter 1.1.

To manage shipments under the conditions of so many interfaces by means of information exchange on the basis of the Directives 2001/14/EC and 2001/16/EC is the final goal of this TSI.

This short explanation of the scope of the conventional rail TSI Telematic Applications for Freight also shows the difference to the Conventional Rail TSI Operation and Traffic Management. The Operation and Traffic Management TSI covers – especially under safety aspects - the procedures and related equipment enabling a coherent operation of the different structural subsystems including, in particular, train driving, traffic planning and management, which is the principal business of an RU according the definition (see chapter 2.3: Overview of the subsystem description).

The TSI Telematic Applications covers the applications for freight services and the management of connections with other modes of transport which means that it concentrates on the transport services of an RU in addition to the pure operation of trains. Safety aspects are only considered as far as the existence of data elements, e.g. wrong or not actual values, may have an impact on the safety operation of a train.

1.2. Geographical Scope

The geographical scope of this TSI is the Trans-European conventional rail system as described in Annex I to the Directive 2001/16/EC. But this TSI may also be applied to the complete freight transport rail network of the member States of the EU, with the restriction that the requirements of this TSI are not mandatory for freight transport arriving from or going to a non-EU country.

1.3. Content of this TSI

In accordance with Article 5(3) of Directive 2001/16/EC, this TSI:

- (a) indicates its intended scope of the Telematic Applications Subsystem for Freight – Chapter 2: Definition of subsystem/scope;
- (b) lays down the essential requirements for this subsystem and its interface vis-à-vis other subsystems – Chapter 3: Essential requirements;
- (c) establishes the functional and technical specifications to be met by the subsystem and its interfaces vis-à-vis other subsystems – Chapter 4: Characterisation of the subsystem;
- (d) determines the interoperability constituents and interfaces covered by European specifications, including European standards, which are necessary to achieve interoperability within the Trans-European Conventional Rail System – Chapter 5: Interoperability constituents;
- (e) states, in each case under consideration, the procedures for the assessment of conformity or suitability for use. This includes, in particular, the modules defined in Decision 93/465/EEC or, where appropriate, the specific procedures to be used to assess either the conformity to or the suitability for use of interoperability constituents

and "EC" verification of subsystems – Chapter 6: Assessment of conformity and/or suitability for use of the constituents and verification of the subsystem;

- (f) indicates the strategy for implementing the TSI. In particular it is necessary to specify the stages to be completed in order to make a gradual transition from the existing situation to the final situation in which compliance with the TSI shall be the norm – Chapter 7: Implementation;
- (g) indicates, for the staff concerned, the professional qualifications and health and safety conditions at work required for the operation and maintenance of this subsystem, as well as for the implementation of the TSI – Chapter 4: Characterisation of the subsystem.

Moreover, in accordance with Article 5(5), provision is made for specific cases for this TSI; these are indicated in Chapter 7.3: Specific cases.

Lastly, this TSI also comprises, in Chapter 4 (Characterisation of the subsystem), the operating and maintenance requirements specific to the scope indicated in paragraphs 1.1 (Technical scope) and 1.2 (Geographical Scope) above.

2. DEFINITION OF SUBSYSTEM/SCOPE

2.1. Function within the scope of the TSI

The subsystem Telematic Applications for Freight is defined by Annex II of the Directive 2001/16/EEC, section 2.5 (b).

It includes in particular:

- Applications for freight services, including information systems (real-time monitoring of freight and trains),
- Marshalling and allocation systems, whereby under allocation systems is understood train composition,
- Reservation systems, whereby here is understood the train path reservation,
- Management of connections with other modes of transport and production of electronic accompanying documents.

2.2. Functions outside the scope of the TSI

Payment and invoicing systems for customers are not within the scope of this TSI, nor are such systems for payment and invoicing between various service providers such as railway undertakings or infrastructure managers. The system design behind the data exchange in accordance with chapter 4.2 (Functional and technical specifications of the subsystem), however, provides the information needed as a basis for payment resulting from the transport services.

Also the long term planning of the timetables is out with the scope of this Telematic Applications TSI. Nevertheless at some points there will be reference to the outcome of the long term planning in so far as there is a relationship to the efficient interchange of information required for the operation of trains.

2.3. Overview of the subsystem description

2.3.1. Involved Entities

This TSI takes into account the present service providers and the various possible service providers of the future involved in freight transport as they are for (this list is not exhaustive):

- Wagons
- Locomotives
- Drivers
- Switching and Hump shunting
- Slot selling
- Shipment management
- Train composition
- Train Operation
- Train monitoring
- Train controlling
- Shipment monitoring
- Inspections & Repair of Wagon and / or Locomotive
- Customs clearance
- Operating Intermodal Terminals
- Haulage management

Some specific service providers are defined explicitly in the directive 2001/14/EC and 2001/16/EC. Since both directives have to be taken into account, this TSI considers in particular the definition of (see also Annex A index 6):

Infrastructure Manager (IM): means any body or undertaking that is responsible, in particular, for establishing and maintaining railway infrastructure. This may also include the management of infrastructure control and safety systems. The functions of the infrastructure manager on a network or part of a network may be allocated to different bodies or undertakings;

Based on this definition, this TSI regards an IM as the service provider for the allocation of paths, for controlling / monitoring the trains and for train / path related reporting.

According to Directive 2001/14/EC the body or undertaking to which an IM allocates a path is defined as an applicant.

Applicant: means a licensed railway undertaking and/or an international grouping of railway undertakings, and, in Member States which provide for such a possibility, other persons and/or legal entities with public

service or commercial interest in procuring infrastructure capacity, such as public authorities under Regulation (EEC) No 1191/69 and shippers, freight forwarders and combined transport operators, for the operation of railway services on their respective territories;

Whereas a Railway Undertaking is defined as any public or private undertaking, licensed according to applicable Community legislation, the principal business of which is to provide services for the transport of goods and/or passengers by rail with a requirement that the undertaking must ensure traction; this also includes undertakings which provide traction only.

Based on this definition, this TSI regards the RU as the service provider for operating trains.

Regarding the allocation of a train path for running a train Article 13 of the Directive 2001/14/EC also has to be taken into account:

Infrastructure capacity shall be allocated by an infrastructure manager, and once allocated to an applicant may not be transferred by the recipient to another undertaking or service. Any trading in infrastructure capacity shall be prohibited and shall lead to exclusion from the further allocation of capacity. The use of capacity by a railway undertaking when carrying out the business of an applicant who is not a railway undertaking shall not be considered as transfer.

In relation to the communication scenarios between infrastructure managers and applicants in the execution mode of a transport, only the IM and the RU have to be considered and not all types of applicants, which may be relevant for the planning mode. In the execution mode a defined IM – RU relationship is always given, for which the message exchange and the information storage is specified in this TSI. The definition of an applicant and the resulting path allocation possibilities remain uninfluenced.

As already mentioned various services have to be provided for a freight transport. One for example is the provision of wagons. This service can be related to a fleet manager. If this service for a transport is one of the services offered by the RU, the RU acts also as Fleet manager. A fleet manager again can manage his own wagons and / or wagons from another keeper (another service provider for freight wagons). The needs for this kind of service provider are taken into account independent of whether the legal entity of the fleet manager is an RU or not.

This TSI does not create new legal entities and does not force an RU to involve external service providers for services which the RU itself offers but it does name, where necessary, a service by the name of a related service provider. If the service is offered by an RU, the RU acts as the service provider for that service.

When taking into account the needs of a customer, one of the services is to organise and manage the transport line according to the commitment to the customer. This service is provided by the Lead Railway Undertaking (Lead

RU or LRU). The LRU is the single point of contact for the customer. If more than one railway undertaking is involved in the transport chain, the LRU is also responsible for the co-ordination with the other railway undertakings.

This service can also be undertaken by a forwarder or by any other entity.

The involvement of an RU as LRU can differ from one type of transport flow to another. In the Intermodal business the managing of capacity in block trains and the preparing of waybills is done by an Intermodal service integrator, who could then be customer for the LRU.

The main point, however, is that the RUs and the IMs and all other Service Providers (in the sense as defined above) must work together, either through co-operation and / or open access, as well as through efficient interchange of information, to deliver seamless services to the customer.

2.3.2. Considered Processes

This TSI for the railway freight transport industry is limited according to Directive 2001/16/EC to IMs and RUs / LRUs with reference to their direct customers.

In the operation of freight services, the activity of an LRU, regarding a consignment, starts with the receipt of the consignment note from its customer and, for example, for wagon loads with the release time of the wagons. The LRU creates a preliminary trip plan (based on experience and / or contract) for the transport journey. If the LRU intends to have the wagon load in a train under Open Access mode (the LRU operates the train for the complete journey), the preliminary trip plan is per se the final one. If the LRU intends to put the wagon load in a train which involves the co-operation of other RUs, he first has to find out which RUs he should address and at what time an interchange between two successive RUs can occur. The LRU then prepares the preliminary wagon orders individually for each RU as subsets of the full consignment note. The wagon orders are specified in chapter 4.2.1 (Consignment Note data).

The addressed RUs check the availability of the resources for the operation of the wagons and the availability of the train path. The responses from the various RUs enable the LRU to refine the trip plan or to start the interrogation anew – perhaps even with other RUs - until the trip plan finally fits customer requirements.

The RUs / LRUs must in general have, at minimum, the capability of,

- DEFINING services in terms of price and transit times, wagon supply (where applicable), wagon / Intermodal unit information (location, status and the wagon / Intermodal unit related estimated time of arrival “ETA”), where shipments can be loaded on empty wagons, containers etc.;

- DELIVERING the service that has been defined in a reliable, seamless manner through the use of common business processes and linked systems. There must be a capability for RUs, IMs and other service providers and stakeholders such as customs to exchange information electronically;
- MEASURING the quality of the service delivered compared to what was defined. i.e. billing accuracy against price quoted, actual transit times against commitments, wagon ordered against supplied, ETAs against actual arrival times;
- OPERATING in a productive manner in terms of utilisation: train, infrastructure and fleet capacity through the use of business processes, systems and data exchange required to support wagon / Intermodal unit and train scheduling.

The RUs / LRUs as an applicant must also provide (through contracts with IMs) the required train path and must operate the train within their journey section. For the train path they may use already booked paths (in planning mode) or they have to request an ad hoc train path from the infrastructure manager(s) (IMs) relevant for the journey section(s) over which the RU operates the train. In Annex A index 5 chapter 1.2 an example is given for the path request scenario.

The path ownership is also important for the communication during the train running between IM and RU. The communication must always be based on train and path number, whereby the IM communicates with the RU, who has booked the train path on his infrastructure (see also Annex A index 5 chapter 1.2).

If an RU provides the complete journey A – F (Open Access by RU, no other RUs are involved), then each IM involved communicates directly with this RU only. This “open access” by the RU can be realised by booking the train path via “One Stop Shop” or in sections with each IM directly. The TSI takes account both cases as it is shown in chapter 4.2.2.1: Path Request, Preliminary remarks.

The dialogue process between RUs and IMs for establishing a train path for a freight train is defined in chapter 4.2.2 (Path Request). This function refers to Article 23(1) of the Directive 2001/14/EC. The dialogue process excludes obtaining the licence for an RU providing services in accordance with Directive 2001/13/EC, the certification according to Directive 2001/14/EC and access rights according to Directive 91/440/EEC.

In chapter 4.2.3 (Train Preparation) is defined the information exchange relating to the train composition and the train departure procedure. The data exchange during the running of a train in the case of normal operation is given in chapter 4.2.4 (Train Running Forecast) and for exceptions the messages are defined in chapter 4.2.5 (Service Disruption Information). Tracing information about train location is defined in chapter 4.2.6 (Train Location). All these messages are exchanged between RU and IM and based on trains.

For a customer the most important information is always the estimated time of arrival (ETA) for his shipment. From the information exchange between LRU and IM (in case of Open Access) an ETA can be calculated. In the case of co-operation mode with various RUs, the ETA and also the estimated times of interchange (ETIs) can be determined from the message exchange between RUs and IMs and provided to the LRU by the RUs, (chapter 4.2.7 Shipment ETI / ETA).

Also determined from the information exchange between IM and RU, the LRU knows for example.

- when the wagons departed from or arrived at a yard or at defined locations (chapter 4.2.8 Wagon Movement) or
- when the responsibility for the wagons was transferred from one RU to the next RU in the transport chain (chapter 4.2.9 Interchange Reporting).

Determined not only from the data exchange between IM and RU, but also from the data exchange between RUs and LRU, various statistics may be evaluated

- for - in the medium term – planning the production process in greater detail and
- for - in the long term - carrying out strategic planning exercises and capacity studies (e.g. network analyses, definition of siding and marshalling yards, rolling stock planning), but above all
- for improving the quality of the transport service and productivity (chapter 4.2.10 Data Exchange for Quality Improvement).

The handling of empty wagons takes on particular relevance when considering interoperable wagons. In principle there is no difference in the handling of loaded or empty wagons. The transport of empty wagons is also based on wagon orders, whereby the fleet manager for these empty wagons must be considered as a customer.

2.3.3. General remarks

An information system is only as good as the reliability of the data within it. Therefore the data that plays a decisive role in the forwarding of a consignment, a wagon or a container must be accurate and captured economically - which means that the data should be entered into the system only once.

Based on this, the applications and messages of this TSI avoid the multiple manual data input by access to already stored data e.g. the rolling stock reference data. The requirements regarding the rolling stock reference data are defined in chapter 4.2.11 (The Main Reference Data). The specified Rolling Stock Reference Databases must allow easy access to the technical data. The contents of the databases must be accessible, based on structured access rights depending on privilege, to all IMs, RUs and Fleet managers, in particular for purposes of fleet management and rolling stock maintenance. They must contain all transport critical technical data such as:

- Identification of rolling stock,
- Technical / design data,
- Assessment of compatibility with the infrastructure,
- Assessment of relevant loading characteristics,
- Brake relevant characteristics,
- Maintenance data,
- Environmental characteristics.

In the Intermodal transport business at various points (called Gateways) a wagon is not only connected to another train, but also the Intermodal unit may be moved from one wagon to another. As a consequence it is not sufficient to work with only a trip plan for wagons and therefore a trip plan for the Intermodal units must also be drawn up.

In chapter 4.2.12 (Various Reference Files) some reference files and various databases are listed, among them, the Wagon and Intermodal Unit Operational Database. This database contains the operational status data of the rolling stock, the weight and dangerous goods information, information related to Intermodal units and the location information. In chapter 4.2.13 (Electronic Transmission of Documents) the requirements for the electronic transmission of documents are given.

The TSI for Telematic Applications subsystem for freight services defines the required information, which has to be exchanged between the different partners involved in a transport chain, and permits a standard mandatory data exchange process to be installed. It shows also the architecture strategy for such a communication platform. This is outlined in chapter 4.2.14 (Networking & Communication) taken into account:

- the interface to the subsystem Operation and Traffic Management of the Trans-European Conventional Rail System referred to in Article 5(3) of the Council Directive 2001/16/EC,
- the requirements for the content of the Network Statement, which are set out in the Directive 2001/14/EC, Article 3 and Annex I,
- the information available on the freight wagon rolling stock and the requirements regarding maintenance from the Rolling Stock TSI.

There is no direct data transmission from the subsystem Telematic Applications for Freight Services into the train, to the driver or to parts of the Control Command and Signalling subsystem and the physical transmission network is a completely different one from the network used by the Command Control and Signalling subsystem. The ERTMS/ETSC system is using GSM-R. In this open Network the ETCS specifications clarify that safety is achieved with the appropriate management of open networks hazards in the EURORADIO protocol.

The interfaces to the structural subsystems Rolling Stock and Control Command are only given via the Rolling Stock Reference Databases (chapter 4.2.11.3: The Rolling Stock Reference Databases), which are under the control of the keepers. The interfaces to the subsystems Infrastructure,

Control Command and Energy are given with the path definition (chapter 4.2.2.3: Path Details message) from the IM, where infrastructure related values for the train are specified, and with the information provided by the IMs regarding restrictions in the infrastructure (chapter 4.2.11.2: The Infrastructure Restriction Notice Databases).

3. ESSENTIAL REQUIREMENTS

3.1. Compliance with the essential requirements

According to Article 4(1) of Directive 2001/16/EC, the Trans-European Conventional Rail System, subsystems and their interoperability constituents must meet the essential requirements set out in general terms in Annex III of the Directive.

In the scope of the present TSI, fulfilment of relevant essential requirements quoted in chapter 3 of this TSI will be ensured for the subsystem by the compliance with the specifications described in chapter 4: Characterisation of the subsystem.

3.2. Essential requirements aspects

The essential requirements concern:

- Safety,
- Reliability and Availability,
- Health,
- Environmental protection,
- Technical compatibility.

According to Directive 2001/16/EC, the essential requirements may be generally applicable to the whole Trans-European Conventional Rail System or be specific to each subsystem and its constituents.

3.3. Aspects relating to general requirements

The relevance of the general requirements to the Telematic Applications Subsystem for Freight is determined as follows:

3.3.1. Safety

In accordance with Annex III to Directive 2001/16/EC, the safety-related essential requirements that apply to the Telematic Applications subsystem for freight are the following:

- Essential requirement 1.1.1 of Annex III to Directive 2001/16/EC:

“The design, construction or assembly, maintenance and monitoring of safety-critical components and, more particularly, of the components involved in train movements must be such as to guarantee safety at the level corresponding to the aims laid down for the network, including those for specific degraded situations.”

This essential requirement is not relevant to the Telematic Applications subsystem.

- Essential requirement 1.1.2 of Annex III to Directive 2001/16/EC:

“The parameters involved in the wheel/rail contact must meet the stability requirements needed in order to guarantee safe movement at the maximum authorised speed.”

This essential requirement is not relevant to the Telematic Applications subsystem.

- Essential requirement 1.1.3 of Annex III to Directive 2001/16/EC:

“The components used must withstand any normal or exceptional stresses that have been specified during their period in service. The safety repercussions of any accidental failures must be limited by appropriate means.”

This essential requirement is not relevant to the Telematic Applications subsystem.

- Essential requirement 1.1.4 of Annex III to Directive 2001/16/EC:

“The design of fixed installations and rolling stock and the choice of the materials used must be aimed at limiting the generation, propagation and effects of fire and smoke in the event of a fire.”

This essential requirement is not relevant to the Telematic Applications subsystem.

- Essential requirement 1.1.5 of Annex III to Directive 2001/16/EC:

“Any devices intended to be handled by users must be so designed as not to impair the safe operation of the devices or the health and safety of users if used foreseeable in a manner not in accordance with the posted instructions.”

This essential requirement is not relevant to the Telematic Applications subsystem.

3.3.2. *Reliability and availability*

“The monitoring and maintenance of fixed or movable components that are involved in train movements must be organised, carried out and quantified in such a manner as to maintain their operation under the intended conditions.”

This essential requirement is met by the following chapters:

- Chapter 4.2.11: The Main Reference Data,
- Chapter 4.2.12: Various Reference Files and Databases,
- Chapter 4.2.14: Networking & Communication.

3.3.3. *Health*

- Essential requirement 1.3.1 of Annex III to Directive 2001/16/EC:

“Materials likely, by virtue of the way they are used, to constitute a health hazard to those having access to them must not be used in trains and railway infrastructure.”

This essential requirement is not relevant to the Telematic Applications subsystem.

- Essential requirement 1.3.2 of Annex III to Directive 2001/16/EC:

“Those materials must be selected, deployed and used in such a way as to restrict the emission of harmful and dangerous fumes or gases, particularly in the event of fire.”

This essential requirement is not relevant to the Telematic Applications subsystem.

3.3.4. *Environmental protection*

- Essential requirement 1.4.1 of Annex III to Directive 2001/16/EC:

“The environmental impact of establishment and operation of the Trans-European conventional rail system must be assessed and taken into account at the design stage of the system in accordance with the Community provisions in force.”

This essential requirement is not relevant to the Telematic Applications subsystem.

- Essential requirement 1.4.2 of Annex III to Directive 2001/16/EC:

“The materials used in the trains and infrastructure must prevent the emission of fumes or gases which are harmful and dangerous to the environment, particularly in the event of fire.”

This essential requirement is not relevant to the Telematic Applications subsystem.

- Essential requirement 1.4.3 of Annex III to Directive 2001/16/EC:

“The rolling stock and energy-supply systems must be designed and manufactured in such a way as to be electro-magnetically compatible with the installations, equipment and public or private networks with which they might interfere.”

This essential requirement is not relevant to the Telematic Applications subsystem.

- Essential requirement 1.4.4 of Annex III to Directive 2001/16/EC:

“Operation of the Trans-European conventional rail system must respect existing regulations on noise pollution.”

This essential requirement is not relevant to the Telematic Applications subsystem.

- Essential requirement 1.4.5 of Annex III to Directive 2001/16/EC:

“Operation of the Trans-European conventional rail system must not give rise to an inadmissible level of ground vibrations for the activities and areas close to the infrastructure and in a normal state of maintenance.”

This essential requirement is not relevant to the Telematic Applications subsystem.

3.3.5. *Technical compatibility*

- Essential requirement 1.5 of Annex III to Directive 2001/16/EC:

“The technical characteristics of the infrastructure and fixed installations must be compatible with each other and with those of the trains to be used on the Trans-European conventional rail system. If compliance with these characteristics proves difficult on certain sections of the network, temporary solutions, which ensure compatibility in the future, may be implemented.”

This essential requirement is not relevant to the Telematic Applications subsystem.

3.4. Aspects relating specifically to the Telematic Applications Subsystem for Freight

3.4.1. Technical compatibility

- Essential requirement 2.7.1 of Annex III to Directive 2001/16/EC:

“The essential requirements for Telematic Applications guarantee a minimum quality of service for passengers and carriers of goods, particularly in terms of technical compatibility.”

Steps must be taken to ensure:

- that the databases, software and data communication protocols are developed in a manner allowing maximum data interchange between different applications and operators, excluding confidential commercial data;
- easy access to the information for users.”

This essential requirement is specially met by the following chapters:

Chapter 4.2.11: The Main Reference Data,
Chapter 4.2.12: Various Reference Files and Databases,
Chapter 4.2.14: Networking & Communication.

3.4.2. Reliability and availability

- Essential requirement 2.7.2 of Annex III to Directive 2001/16/EC:

“The methods of use, management, updating and maintenance of these databases, software and data communication protocols must guarantee the efficiency of these systems and the quality of the service.”

This requirement is specially met by the following chapters:

Chapter 4.2.11: The Main Reference Data,
Chapter 4.2.12: Various Reference Files and Databases,
Chapter 4.2.14: Networking & Communication.

But this essential requirement, especially the method of use to guarantee the efficiency of these Telematic applications and the quality of the service, is the foundations for the complete TSI and not only restricted to the chapters mentioned above.

3.4.3. Health

- Essential requirement 2.7.3 of Annex III to Directive 2001/16/EC:

“The interfaces between these systems and users must comply with the minimum rules on ergonomics and health protection.”

This TSI does not specify any additional requirements to existing national and European rules related to minimum rules on ergonomics and health protection of an interface between these Telematic applications and users.

3.4.4. *Safety*

- Essential requirement 2.7.4 of Annex III to Directive 2001/16/EC:

“Suitable levels of integrity and dependability must be provided for the storage or transmission of safety-related information.”

This requirement is met by the following chapters:

- Chapter 4.2.11: The Main Reference Data,
- Chapter 4.2.12: Various Reference Files and Databases,
- Chapter 4.2.14: Networking & Communication.

4. CHARACTERISATION OF THE SUBSYSTEM

4.1. Introduction

The Trans-European conventional rail system, to which Directive 2001/16/EC applies and of which the Telematic Applications Subsystem is a part, is an integrated system whose consistency must be verified. This consistency must be checked in particular with regard to the specifications of the subsystem, its interfaces vis-à-vis the system in which it is integrated, as well as the operating and maintenance rules.

Taking into account all the applicable essential requirements, the Telematic Application Subsystem for Freight is characterised by:

4.2. Functional and technical specifications of the subsystem

In light of the essential requirements in Chapter 3 (Essential requirements), the functional and technical specifications of the subsystem are as follows:

- Consignment Note data,
- Path Request,
- Train Preparation,
- Train Running Forecast,
- Service Disruption Information,
- Train Location,
- Wagon / Intermodal unit ETI / ETA,
- Wagon Movement,
- Interchange Reporting,
- Data Exchange for Quality Improvement,
- The Main Reference Data,
- Various Reference Files and Databases,
- Electronic Transmission of Documents,
- Networking & Communication.

The detailed specifications are outlined below. Further details and the formats of the messages are defined in Annex A index 1.

General remarks on the message structure

The messages are structured into two data sets:

- Control data: explanation see below
- Information data: the application information

The control data show the following elements:

- Status: The status of a message can be:
 - “New message”, if this is a new message
 - “Alteration”, if this is a modification of a previous send message
 - “Deletion”, if the previous sent message should be deleted.
- Message Reference with:

Message Type: e.g. “path request” or “enquiry about train running”.

Data and Time: actual date and time when the message was sent.

Message Number: number generated by the sender of the message

- Related Reference, only if the message is the answer to a previous received message (identical to the “Message Reference” of the received message.) with:

Related Type: type of the received message

Related Date and Time: Date and time of the received message

Related Number: number of the received message

- Sender of the message
- Recipient of the message

In the following chapters mainly the status “New message” is considered. In chapter 4.2.2 Path Request is also referred to the status “deletion” regarding the Path Request message.

4.2.1. *Consignment Note data*

4.2.1.1. Customer Consignment Note

The Consignment Note has to be sent by the Customer to the Lead RU. It must show all the information needed to carry a consignment from the consignor to the consignee. The LRU must supplement this data with additional information. These data, including the additional ones, are (for the description of the data see Annex A index 3) listed in the table in Annex A index 3 with the indication in row “Data in Consignment Note”, whether they are mandatory or optional and whether they must be delivered by the Consignor or supplemented by the LRU.

In the case of Open Access the Lead RU contracting with the customer has all the information after the supplement of the data available. No message exchange is needed with other RUs. These data are also the basis for a path request on short notice, if this is required for the execution of the consignment note.

The following messages are for the case of non Open Access. The content of these messages may also be the basis for the path requests on short notice, if required for the execution of the consignment note.

4.2.1.2. Wagon Orders

The wagon order is primarily a subset of the Consignment Note information. It must be forwarded to the RUs involved in the transport chain, since it could become an input for an ad hoc path request (chapter 4.2.2: Path Request). The content of the Wagon Order must show the relevant information which is needed for an RU to effect transportation during its responsibility until handover to next RU. Therefore the content is dependent on the role to be performed by the railway undertaking: Origin-, Transit- or Delivery RU (ORU, TRU, DRU).

- Wagon Order for the Origin Railway Undertaking (ORU),
- Wagon Order for the Transit Railway Undertaking (TRU),
- Wagon Order for the Delivery Railway Undertaking (DRU).

The data of the wagon orders according the various roles of an RU are listed in detail in Annex A index 3, marked as to whether they are mandatory or optional. The detailed formats of these messages are defined in Annex A index 1.

The main contents of these wagon orders are:

- Consignor and consignee information,
- Routing information,
- Consignment identification,
- Wagon information,
- Place and time information.

Selected data of the consignment note data must also be accessible for all partners (e.g. IM, Keeper...) in the transport chain including customers, These are especially per wagon:

- Load weight (Gross weight of the load),
- CN/HS Number,
- Dangerous goods information,
- Transportation unit.

4.2.2. *Path Request*

4.2.2.1. Preliminary remarks

Long term planning

The Train Path defines the requested, accepted and actual data to be stored concerning the path of a train and the characteristics of the train for each segment of that path. The following description presents the information which must be available to the infrastructure manager. For a more detailed description see Annex A index 4.

This information must be updated whenever a change occurs.

The main Path data must be:

- Identification of the train path (path number). A path could be either planned usage of capacity along a route section, or the actual routing of a train along a specified line within a route. The exact nature depends upon the processes in use within an IM.
- Path Departure Point, which means the place from where the path will start together with the Date and Time of the departure of a train on that path.
- Destination of the train path, which means the place where the path will end together with Date and Time at which a train is due to arrive at that destination.
- Description of the Journey Section, which defines the data provided by the IM for each accepted journey section - from the start to the first intermediate stop, further intermediate stops and from the final intermediate stop to the end of the accepted journey. This description may comprise:
 - Intermediate stops or other designated points along the proposed path with date and time for the arrival, departure or passage at these intermediate points as well with an Activity Code, which defines an activity to be undertaken at that intermediate point en route,
 - Identification of the IM responsible for the traffic management for the current journey section and identification of the IM responsible for the traffic management for the next journey section,
 - Description of the equipment (Command and control system, radio system, etc) to be carried by the train; this must be compatible with the infrastructure to enable traction, control and communications from the train to IM control,
 - Train related data for the journey section: max. weight, max. length, max speed, max axle weight, min brake force, max weight per metre, information concerning exceptional gauging, identifiers of not allowed dangerous goods,

- Path number,
- Additional route section running time to allow for recovery, path problems, etc.

Execution Path Contract: Before the running of a train, the journey section must be updated and completed with actual values. The execution mode is independent from the planning mode.

Path Request on short notice

Due to exceptions during the train running or due to transport demands on a short time basis, a railway undertaking must have the possibility to get an ad hoc path on the network.

In the first case, immediate actions have to be started, whereby the actual train composition based on the train composition list is known.

In the second case, the railway undertaking must provide the infrastructure manager with all necessary data concerning when and where the train is required to run together with the physical characteristics in so far as they interact with the infrastructure. These data are mainly given in the supplemented consignment note respectively in the wagon orders.

The Path agreement for a train movement at short notice is based on a dialogue between RUs and IMs. The dialogue will involve all RUs and IMs involved in moving the train along the desired path but maybe with different contribution to the path finding process. According to Directive 2001/14/EC article 13, mainly two general valid different scenarios can be distinguished for freight transport operating on the infrastructures of several IMs (see also Annex A index 5 chapter 1.3).

- Scenario A: The RU contacts all involved IMs directly (case A) or via the OSS (case B) to organise the paths for the complete journey. In this case the RU has also to operate the train on the complete journey according to Article 13 of the Directive 2001/14/EC.
- Scenario B: Each RU involved in the Transport Journey contacts the local IMs directly or via OSS to request a path for the journey section on which it operates the train.

Remark: As already mentioned in chapter 2 (Definition of subsystem/scope), in the execution mode, the IM will always communicate with the RU which has booked the path. Therefore the “path ownership” is important for the message exchange during operation of the train.

In both scenarios the booking procedure of a path on short notice follows the dialog between RU and IM involved as described on the next page.

The following table shows the messages used in the dialogue for the path request:

Message	Explanation
Messages used in the dialogue for the path request	
Path Request	RU to IM(s) involved, this message must be sent for a path request at short notice.
Path Details	This message must be sent from IM(s) to RU confirming details of path in response to RU's "Path Request", perhaps with changed values or if the IM cannot serve the path request, with the indication "No alternatives available".
Path Confirmed	This message must be sent from the RU to the IM for the acceptance of the "Path Details" from the IM in response to the RU's original request.
Path Details Refused	This message must be sent from the RU to the IM when not accepting the "Path Details" from the IM in response to RU's original request, if there are changed values, which the RU cannot accept.

Table 1: Path Request

This dialogue ends with the RU by the Path Confirmed message or with the deletion of the path request (Path Request message with status "Deletion", see chapter 4.2: Functional and technical specifications of the subsystem, General remarks on the message structure). A Path Details Refused message from the RU must always be served with a new Path Details message. If the IM cannot serve the path request with a new proposal within the "Path Details" message, he must send the Path Details message with the indication "No alternatives available", which ends the dialogue with the IM.

Whether the path was booked in the long term planning or on a short notice, the RU must have always the possibility to cancel a booked path. For the cancellation of a booked path the following message must be used.

Message	Explanation
Message to cancel a booked path by RU	
Path Cancelled	Advice from the RU to the IM to cancel a previously booked path or a part of it.

Table 2: Path Cancellation by RU

Based on the path agreement, the RU can expect that a booked path is also available. Therefore if something occurs and the booked path is no longer available, the IM must inform the RU as soon as it has the knowledge about this fact. A cause of this may be for example an interruption on the path. This can happen at any time between the moment the train path is contracted and the departure of the train. The IM is obliged to send an alternative proposal together with the indication “path not available”. If this is not possible the IM must send the proposal as soon as possible. With the Path Not Available message a dialog starts for a new path agreement initiated by the IM.

Messages used in the dialog for the cancellation of a booked path by IM.

Message	Explanation
Messages used in the Path cancellation process initiated by IM	
Path Not Available	Advice from the IM to the RU that the booked path is not available
Path Details	This message must be sent from IM(s) to RU proposing an alternative path after the advice from the IM to the RU that the booked path is not available.
Path Confirmed	This message must be sent from the RU to the IM for the acceptance of the path proposed in the Path Not Available message.
Path Details Refused	This message must be sent from the RU to the IM when not accepting the proposal from the IM in the Path Not Available message. In this case the IM must send a new proposal. This dialog ends by the RU with the “Path Cancelled” message related to IM’s “Path Not Available” message.

Table 3: Path Cancellation by IM

In general, if the receiver of a request or enquiry can not answer in real time he must inform the originator of the message (for example the Path Details message as response to the Path Request can not be sent immediately). This must be done by using the following message:

Message	Explanation
This message is valid in general	
Receipt Confirmation	This message must be sent from the recipient of a message to the originator of the message when the required response cannot be made available within the time interval as defined in chapter 4.4 (Operating rules) section “Timeliness”.

Table 4: Receipt Confirmation

These messages are described by mentioning the main points in the following chapters. The detailed formats are defined in Annex A index 1. The logical sequence of these messages is shown in the diagrams in Annex A index 5 chapter 2.1 to 2.3.

4.2.2.2.Path Request message

This is the Request from the RU to the IM for a train path. Such a request must contain

- Path Departure Point: Place from where the proposed path will start,
- Path Departure Date / Time: Date / Time for which the path is requested,
- Path Destination Point: Destination of Train for the requested path,
- Path Destination Arrival Date / Time: Date / Time at which the proposed train is due to arrive at its destination,
- Requested Journey Section:
 - Intermediate stops or other designated points along the proposed path with Date / Time at which the proposed train is due to arrive at an intermediate point and the Date / Time that the train is due to depart from an intermediate point. A blank entry indicates that it will not stop at that point,
 - Available Equipment on the train: Traction Type, Command and Control System including On Board Radio Equipment,
 - Train Weight,
 - Train Length,
 - Braking System to be used and braking performance,
 - Max Speed of the train,
 - Maximum Axle Weight of the train,
 - Maximum Weight per metre,
 - Information concerning exceptional gauging,
 - UN / RID Numbers relating to any dangerous goods,

- Definitions of activity to be undertaken at any intermediate point en route,
- Responsible RU: Identification of the RU responsible for the train for the current journey section,
- Responsible IM: Identification of the IM responsible for the train for the current journey section,
- Next Responsible IM: Identification of the IM responsible for the train for the next journey section (if any).

As an information support for the formulation of the path request, the RU can consult the relevant Network Statement to check whether the data of the train in mind comply with the infrastructure. Data such as dangerous goods information also has to be taken into account.

The keepers of the wagons must give the RUs access to the technical wagon data.

The RUs must themselves ensure access to the reference files e.g. to the dangerous goods reference file if required.

4.2.2.3.Path Details message

This message is the answer from an IM to the “Path request” message from an RU. In the case that the IM cannot serve the path request, he must send this message with the indication “No alternatives available”. In the other case he must answer the RU request by sending back a path number together with the same data as in the train path request but perhaps with changed values.

For the alternative proposed by IM the following data must be sent:

- New Path Number,
- Path Departure Point: Place from where the proposed path will start,
- Path Departure Date / Time: Date / Time for which the path is proposed,
- Path Destination Point: Destination of Train for the proposed path,
- Path Destination Arrival Date / Time: Date / Time at which the train is due to arrive at its destination,
- Modified Journey Section:
 - Intermediate stops or other designated points along the proposed path with Date / Time at which the proposed train is due to arrive at an intermediate point and the Date / Time that the train is due to depart from an intermediate point. A blank entry indicates that it will not stop at that point,
 - Required Equipment on the train: Traction Type, Command and Control System including On Board Radio Equipment,
 - Train Weight,
 - Train Length,
 - Braking System to be used and braking performance,
 - Max Speed of the train,
 - Maximum Axle Weight of the train,

- Maximum Weight per metre,
- Information concerning exceptional gauging,
- UN / RID Numbers relating to any dangerous goods,
- Definitions of activity to be undertaken at any intermediate point en route,
- Responsible RU: Identification of the RU responsible for the train for the current journey section,
- Responsible IM: Identification of the IM responsible for the train for the current journey section,
- Next Responsible IM: Identification of the IM responsible for the train for the next journey section (if any).

4.2.2.4.Path Confirmed message

This message must be sent from an RU to an IM accepting a proposed path in response to the RU's original request. With this message the path is booked. The main message content is:

- Path Number to identify the path,
- Path Departure Point: Place from where the train will depart,
- Path Departure Date / Time: Date / Time for which the path is requested,
- Path Destination Point: Train Destination for the requested path,
- Path Destination Arrival Date / Time: Date / Time at which proposed train is due to arrive at its destination,
- Indicates that the RU has accepted the proposed path.

4.2.2.5.Path Details Refused message

In the case of a refusal of the proposed path as given in the "Path Details" message by the IM, the RU must send this message to the IM to advise him, that it does not accept the proposed path as given in the "Path Details" message. The main data are:

- Path Number to identify the path,
- Indicates the refusal of the path details.

As additional information the following data may be sent:

- Path Departure Point: Place from where the train will depart,
- Path Departure Date / Time: Date / Time for which the path is requested,
- Path Destination Point: Destination of Train for the requested path,
- Path Destination Arrival Date / Time: Date / Time at which the proposed train is due to arrive at its destination.

4.2.2.6.Path Cancelled message

This is the RU advice to cancel a previously booked path. Together with the cancellation indicator (corresponds to the message type), the path number

must be sent for the unique identification of the path. This applies to path booking in planning mode and on short notice:

- Path Number to identify the path,
- Train Number (if already known to the IM),
- Indicates the cancellation of the booked train path.

As additional information the following data may be sent:

- Path Departure Point: Place from where the train will depart,
- Path Departure Date / Time: Date / Time for which the path is requested,
- Path Destination Point: Destination of Train for the requested path,
- Path Destination Arrival Date / Time: Date / Time at which the proposed train is due to arrive at its destination.

4.2.2.7.Path Not Available message

The IM must inform the RU as soon as it has the knowledge, that a train path is not available. The message Train path not available can be send at any time between the moment the train path is contracted and the departure of the train. A cause of this message may be e.g. an interruption on the path. The main contents of this message are:

- Path number of the path which is not available,
- Train number of the train foreseen for the cancelled path (if already known to the IM),
- Path Departure Point with Date and Time for which path was booked,
- Path Destination Point with Date and Time at which the train is due to arrive at its destination,
- Train Path Not Available Indication,
- Indication of the cause.

Together with this message or as soon as possible the IM must send without any further request from the RU an alternative proposal. This is done with the message "Path Details" related to this "Path Not Available" message.

4.2.2.8.Receipt Confirmation message

This information must be sent from the recipient of a message to the originator of the message, when the required response cannot be made available within the time frame as specified in chapter 4.4 (Operating rules). This message must have an identifier to which it refers (entries in Related Message, see chapter 4.2: Functional and technical specifications of the subsystem, General remarks on the message structure) and the indication: (Application level)

- Message Confirmation: Indicates that the recipient has received the message and will act upon it as necessary.

4.2.3. Train Preparation

4.2.3.1. General Remarks

This section specifies the messages which must be exchanged during the train preparation phase until the start of the train. The messages are shown below in table 5.

For the preparation of the train, the RU must have access to the infrastructure restriction notices, to the technical wagon data (Rolling Stock Reference Databases, chapter 4.2.11.3: The Rolling Stock Reference Databases), to the dangerous goods reference file and to the current, updated information status on the wagons (chapter 4.2.12.2: Other Databases: The Wagon and Intermodal Unit Operational Database). This applies to all wagons on the train. At the end the RU must send the train composition to the next RUs. This message must also be sent from the RU to the IM(s) with whom it has booked a path section, when requested by the Conventional Rail TSI Operation and Traffic Management or by the contract(s) between RU and IM(s).

If the train composition is changed at a location, this message must be exchanged once more with information updated by the RU responsible.

At each point e.g. origin and interchange point, where the responsibility changes on the RU side, the start procedure dialogue between IM and RU “Train ready – Train Running Information” is obligatory.

The messages used within this start procedure dialogue are:

Message		Explanation	
Train Composition		RU to IM, this message must be sent according the description above.	
In the case that the IM has received a train composition message send mandatory by the RU, the IM may send:			
Train Accepted	IM to RU: This message is optional, if nothing else is agreed between IM and RU	Train preparation can be completed	
Train not Suitable	IM to RU: This message may be sent by the IM, if this is detected by him.	RU possibilities: modify the train composition or Cancel train path and Request new path	

Train Ready	RU to IM, this message must be sent
Train Position	IM to RU, defines exactly where and when the train must present itself on the network This message may be sent depending on national rules.
Train at Start	RU to IM, This message may be sent to indicate that the train has started its journey as response on the message: Train Position. This message may be sent depending on national rules.
Train Running Information	IM to RU, This message must be sent to indicate that the train has arrived on the infrastructure

Table 5: Train Preparation

These messages are described by mentioning the main points in the following chapters. The detailed formats are defined in Annex A index 1. The logical sequence is shown in Annex A index 5 chapter 3.

Remark: During the train preparation also a Train Path Not Available message can occur, since this message can be send at any time between the moment the train path is contracted and the departure of the train. The procedure for this is described in chapter 4.2.2 (Path Request).

4.2.3.2. Train Composition message

This message must be sent from the RU to the next RU, defining the composition of the train. This message must also be sent from the RU to the IM(s) when requested by the Conventional Rail TSI Operation and Traffic Management or by the contract between IM and RU. Whenever there is a change in the composition during the journey of a train, the RU responsible has to update this message to all parties involved.

The information, which must be transmitted and be accessible, is;

- Train number and Path Number to identify the path,
- Path Departure Point and Date and Time for which the path was requested,
- Path Destination Point and Date and Time at which the proposed train is due to arrive at its destination,
- Loco(s) identification and position of loco(s) in the train,
- Train length, Train Weight, max. speed of the train,
- Train Composition with the sequence of Vehicle Ids,
- Command and Control System including type of radio equipment,
- Information concerning exceptional gauging,
- UN / RID Numbers of dangerous goods,

- Indication if livestock and people (other than the train crew) will be carried,
- Braking System to be used,
- Wagon data.

After the receipt of the train composition the IM may verify the entries against the contracted path, if the contract between IM and RU explicitly allows this. In that case the IM must have easy access to the information about possible restrictions in the relevant infrastructure, to the technical wagon data (chapter 4.2.11.3: The Rolling Stock Reference Databases), to the dangerous goods reference file and to the current, updated information status on the wagons (chapter 4.2.12.2: Other Databases, Wagon and Intermodal Unit Operational Database). This refers to all wagons on the train. In that case also, the IM, who manages his train paths and keeps up the actual status of the path information must add the train details of the train composition to the path and train data as mentioned in chapter 4.2.2.1 (Path Request, Preliminary remarks).

4.2.3.3. Train Accepted message

Depending on the contractual agreement between the IM and the RU and on regulatory requirements, the IM may also advise the RU if the train composition is acceptable for the booked path. This is effected with this message.

The main contents of this message are:

- Train and path number,
- Path Departure Point with Date and Time for which the path was requested,
- Path Destination Point with Date and Time at which the proposed train is due to arrive at its destination,
- Indication that the IM has accepted the train composition as being suitable for the agreed path.

4.2.3.4. Train not Suitable message

If the train is not suitable for the previously agreed path, the IM may inform the RU, with this message. In this case the RU must recheck the train composition. The main contents of this message are:

- Train and path number,
- Path Departure Point with Date and Time for which the path was requested,
- Path Destination Point with Date and Time at which the proposed train is due to arrive at its destination,
- Not Suitable Indication, which indicates that the train does not match the allocated path and therefore may not run,
- Indication of the cause.

4.2.3.5. Train Ready message

This message must be sent from RU to IM indicating that the train is ready for access to the network. The main contents of this message are:

- Train and path number,
- Path Departure Point with Date and Time for which the path was requested,
- Path Destination Point with Date and Time at which the proposed train is due to arrive at its destination,
- Train ready indication, which indicates that the train has been prepared and is ready to run,
- Control Contact Id for all ship to shore communications,
- If the contractual arrangement between RU and IM does not require the “Train position / Train at start” message exchange, the Train Journey Start Date / Time, which informs the IM of the forecasted Date / Time at which the train will present itself to the network, must be defined in this message. In the case of the required message exchange “Train position / Train at start”, this data element must not be transmitted.

4.2.3.6. Train Position message

This message may be sent from the IM to the RU defining exactly when and where the train should present itself to the network as an answer to the train ready message. The transmission of this message depends on the contractual arrangement between the RU and the IM. In case where the transmission is needed, the main contents of this message are:

- Train and path number,
- Path Departure Point with Date and Time for which the path is requested,
- Path Destination Point with Date and Time at which the proposed train is due to arrive at its destination,
- Track identification, which informs the RU of the track id on which the train should present itself to the network,
- Train Journey Start Date / Time, which informs the RU of the precise Date / Time at which the train should present itself to the network,
- Control Contact Id.

4.2.3.7. Train at Start message

This message may be sent from the RU to the IM when having received a “train position” message from the IM, to indicate that the train has started its journey. This message must have an identifier to which it refers and the indication:

- Train at Start: Date / Time train actually started journey.

4.2.3.8. Train Running Information

As soon as the train is present on the IM infrastructure, which means that the train has left the departure station, the IM sends this message to the RU who has booked the path. This message is described in chapter 4.2.4 (Train Running Forecast).

4.2.4. *Train Running Forecast*

4.2.4.1. General Remarks

This section specifies the messages which must be exchanged during the normal running of a train without any interruption.

The relevant messages are:

Train Running Forecast,
Train Running Information.

This information exchange between RUs and IMs always takes place between the IM in charge and the RU, who has booked the path on which the train is actually running. In the case of Open Access, which means that the paths for the complete journey are booked by one RU (this RU also operates the train during the complete journey), all messages are sent to this RU. The same is true, if the paths for the journey are booked by one RU via OSS.

For further consideration the following scenarios will be differentiated, taking into account the various communication relations between RUs and IMs according to the path booking scenarios of chapter 4.2.2.1 (Path Request, Preliminary remarks scenario A , B):

- Train Approaching a Handover Point between IM n1 and his neighbour IM n2

It is supposed that the handover point is not also an interchange (only scenario B) nor a handling Point. Thus, the handover point is a point on the booked paths of one RU and the RU has already sent the train composition to IM n2, whilst simultaneously sending this message to IM n1.

IM n1, after departure from the departure point¹, must send a train running forecast message to IM n2 with the estimated handover time (ETH). This message is simultaneously sent to the RU.

When the train leaves the infrastructure of IM n1 at the handover point this IM sends a Train running information with the actual handover time at this point to its path contracted RU.

When the train arrives on the infrastructure of IM n2 at the handover point this IM sends a Train running information with the actual handover time from this point to its path contracted RU.

¹ Under departure point the start point of the path is understood, which can be the train departure point for the journey or an Interchange point. The handover point is the end point of the path.

- Train Approaching an Interchange Point between RU 1 and the next RU 2 (only scenario B)

In the path contract an interchange point must always be defined as a reporting point. (*TETAs at reporting points will be generated by the IMs as specified in their contracts with the RUs.*)

For this point the IM in charge sends, once the train left the previous reporting point, a train running forecast message with the TETA for this interchange point to the RU which has contracted the path with him (e.g. RU 1). RU 1 transfers this message to the next RU (e.g. RU 2) supposed to take over the train. Additionally, this message is also sent to the Lead RU (LRU) for the transport if there is one and if this is defined in the co-operation contract between both RUs.

If the interchange point is also a handover point between e.g. IM n1 and IM n2, IM n1 sends the train running forecast message already after departure from the departure point or from the previous interchange point to IM n2 with the estimated handover time (ETH). This message is also sent to the RU having contracted the path e.g. RU 1. For the RU the ETH is equal to the TETA at the interchange point. RU 1 transfers this message to its neighbour RU 2 and to the Lead RU for the transport if there is one and if this is defined in the co-operation contract between both RUs.

When the train arrives at an interchange point, the IM must send a Train running information to his path contracted RU, for example RU 1, with the actual time of the arrival at that point.

Before the train leaves the interchange point, RU 2 must send a new train composition message to the IM having allocated the path and follow the departure procedure as defined in chapter 4.2.3 (Train Preparation).

- Train Approaching a Handling Point of an RU (scenario A)

A Handling Point must always be defined in the path contract as a reporting point.

For this point the IM in charge must send a train running forecast message with a TETA only if this is specified in contract between IM and RU.

But if the Handling Point is also a handover point between, for example, IM n1 and IM n2, IM n1 must send the train running forecast message after departure from the departure point or from the previous interchange to IM n2 with the estimated handover time (ETH). This message is also sent to the RU. For the RU the ETH is equal to the TETA at the Handling Point.

When the train arrives at the Handling Point, the IM must send a Train running information with the actual time of arrival at this point to the RU.

Before the train leaves the Handling Point the RU and IM must follow the departure procedure as defined in chapter 4.2.3 (Train Preparation).

- Train arrival at Destination

When the train arrives at its destination the IM responsible sends a Train running information message with the actual arrival time to the RU which contracted the path.

Remark: In the path contract other locations may also be defined for which a train running forecast with TETA and train running information messages with the actual time are requested. For these points the IM in charge sends these messages as specified in the contract. The further evaluation and processing of the delivered ETHs and TETAs is described in the chapters 4.2.7 (Shipment ETI / ETA) to 4.2.9 (Interchange Reporting).

In the following chapters the message “Train Running Forecast” and “Train Running Information” are described by mentioning only the main contents. The detailed formats are defined in Annex A index 1. The logical sequence of this message exchange relating to the different communication scenarios is shown in Annex A index 5 chapter 4 with the remark, that regarding the communication relation between RU and IMs for train running, the two path request scenarios A(case A) and A(case B) (chapter 4.2.2.1: Path Request, Preliminary remarks) are identical, because in both cases the IMs know only one RU e.g. RU1 which operates the complete path and is also responsible for new train composition at the handling points.

4.2.4.2. Train Running Forecast message

This message must be issued by the IM for handover points, interchange points and for the train destination as described in chapter 4.2.4.1 (Train Running Forecast, General Remarks).

In addition, the message must be issued by the IM to the RU for other reporting points according the RU/IM contracts (e.g. for handling points).

The main data elements are:

- Path number and Train number,
- Scheduled departure Date and Time at IM location (or scheduled handover time to next IM),
- Reporting Point identification,
- Forecasted Date/Time at Reporting Point.

4.2.4.3. Train Running Information message

This message must be issued upon:

- Departure from departure point , arrival at destination,
- Arrival and departure at handover points, interchange points and at agreed reporting points based on contract (e.g. handling points).

The main data elements are:

- Path number and Train number,
- Scheduled departure Date and Time at IM location,

- Most recent reporting point identification,
- Actual Time at reporting point,
- Train Reporting Point Status (Arrival, Departure, Passage, Not Specified, Departure from Origin, Arrival at Destination),
- Arrival track at location,
- Departure track from location,
- Booked Scheduled Time Delta deviation minutes,
- current schedule if multiple re-schedules,
- *For each deviation from Booked Scheduled Time at that reporting location....*
 - Reason code (perhaps multiple),
 - Deviation time for this reason code (multiple reasons may be posted per reporting point),
 - May add free Text about deviation.

4.2.5. *Service Disruption Information*

4.2.5.1. General Remarks

When the RU learns about a service disruption during the train running operation for which it is responsible, it must immediately inform the IM concerned (no IT-message, e.g. orally by the driver). If necessary the RU updates the Wagon and Intermodal Unit Operational Database. If necessary the IM updates the infrastructure data in the Infrastructure Restriction Notice Database and / or the path, respectively the train database.

If the delay exceeds x minutes (This value must be defined in the contract between RU and IM) the IM concerned must send to the RU a train running forecast message relating to the next reporting point.

If the train is cancelled, the IM sends a train running interrupted message as specified below.

In the cases of exceptions where the RU or the IM is not able to run the train at the forecasted time, a new path according chapter 4.2.2 (Path Request) must be negotiated.

4.2.5.2. Train Running Interrupted message

If the train is cancelled this message is issued by the IM to the neighbouring IM and to the path contracted RU.

The main data elements in this message are:

- Path and train number,
- Location identification,
- Scheduled Departure Date and Time at this location,
- Interruption reason,
- Interruption description.

4.2.6. Train Location

4.2.6.1. Preface

This section specifies the tracing possibility to get information about train location. The RU may send an enquiry to the IM about its trains at any time. The RU may enquire about:

- the running of the train (last recorded location, delays, delay reasons),
- a train's performance (delays, delay reasons, delay locations),
- all identifiers of a specified train,
- train forecast at a specified location,
- all train running forecasts for a specified location.

The access to this information must be independent from the communication relation RU / IM during the train running, which means that the RU must have a single² access address to this information. The information is based mainly on the stored message exchange as mentioned above.

4.2.6.2. Enquiry about the Train Running messages

Purpose: RU to enquire on the last recorded status (location, delays and delay reasons) of one specific train on the infrastructure of a specified IM.

Enquiry: Main data elements:

- Train running number,
- IM identifier,
- Scheduled departure Date and Time at IM location.

Response: Information data:

- Most recent reporting location,
- Actual Time at reporting point,
- Train Reporting Point Status (Arrival, Departure, Passage, Not specified, Departure from Origin, Arrival at Destination),
- Arrival track at location,
- Departure track from location,
- Booked Scheduled Time,
- Booked Scheduled Time Delta delay,
- Re-scheduled Time (against current schedule if multiple re-schedules),
- *For each delay at that reporting location...*

² This means, that the access to this information must be independent from which IM has stored the information or part of it.

- Reason code and Delay time for this reason code.

4.2.6.3. Enquiry about the train delay / performance messages

Purpose: RU to enquire on all of the delays to a specific train with a particular IM.

Enquiry: Main data elements:

- Train running number,
- IM identifier,
- Scheduled departure Date and Time at IM location.

Response: Information data (same information as with “Enquiry about train running”, not only for the most recent point but for each reporting point of the train on the infrastructure of the specified IM):

- *For each reporting point....*
 - Most recent reporting location,
 - Actual Time at reporting point,
 - Train Reporting Point Status (Arrival, Departure, Passage, Not Specified, Departure from Origin, Arrival at Destination),
 - Arrival track at location,
 - Departure track from location,
 - Booked Scheduled Time,
 - Booked Scheduled Time Delta delay,
 - Re-scheduled Time (against current schedule if multiple re-schedules),
 - *For each delay at that reporting location...*
 - Reason code and Delay time for this reason code.

4.2.6.4. Enquiry about Train Identifier messages

Purpose: RU to enquire about the current train identifier and its previous train identifiers. Any of the train identifiers for a specific train can be used for the enquiry.

Enquiry: Main data elements:

- Known Train running number,
- IM identifier,
- Scheduled departure Date and Time at the IM location.

Response: Information data:

- *Current train identifier...*
 - Train running number,
 - Scheduled departure Date and Time at the IM location,
- *For each other train identifier*
 - Train running number,

- Scheduled departure Date and Time at the IM location.

4.2.6.5. Enquiry to IM about the Train Forecast messages

Purpose: RU to enquire about the forecast time for a specified train at a particular reporting location or by missing out the reporting location, to enquire on the forecast time at the handover point from the IM.

Enquiry: Main data elements:

- Train running number,
- Scheduled departure Date and Time at IM location,
- Reporting location identifier (The reporting location for which the forecast is required. This is optional and, if not stated, the response refers to the final reporting point for that IM for this train.).

Response: Information data:

- IM code,
- Reporting point identification,
- Forecasted Date/Time at Reporting Point.

4.2.6.6. Enquiry to IM about Trains at Reporting Location messages

Purpose: RU to enquire about all his trains at a particular reporting location on the infrastructure of a specific IM.

Enquiry: Main data elements:

- IM code,
- Reporting location identification (The reporting location for which the forecast is required. This is optional and, if not stated, the response should be the final reporting point for that IM for this train.).

Response: Information data:

- *For each of this enquirer's Trains*
 - Train running number,
 - Scheduled departure Date and Time at IM location or scheduled handover time,
 - IM code,
 - Reporting point identification,
 - Forecasted Date/Time at Reporting Point.

4.2.7. *Shipment ETI / ETA*

4.2.7.1. Preliminary remark

The chapters 4.2.2 (Path Request) through to 4.2.6 (Train Location) have mainly described the communication between the RU and the IM. Since the task of the infrastructure manager is the monitoring and control of the trains the key element for this communication is the train number. The wagon information part of the train composition message is relevant for checking the train composition against the IM/RU path-contract and in cases of exceptions.

The individual monitoring of wagons or Intermodal units is not covered by this information exchange. This is done on the RU / LRU level based on the train related messages and is described in the following chapters 4.2.7 (Shipment ETI / ETA) to 4.2.9 (Interchange Reporting).

The wagon or Intermodal unit related information exchange and updating are essentially supported by storage of “trip plans” and “wagon movements” (chapter 4.2.12.2: Other Databases).

As already mentioned in chapter 2.3.2 (Considered Processes), for a customer the most important information is always the estimated time of arrival (ETA) for his shipment. The wagon related ETA as well as the ETI is also the basic information in the communication between LRU and RU. This information is the main instrument for the LRU to monitor the physical transport of a shipment and to check it against the commitment to the customer.

The forecasted times in the train related messages are all related to an arrival of a train at a certain point, which may be a handover point, interchange point, the train destination or another reporting point. These are all Train Estimated Times of Arrivals (TETA). For the various wagons or Intermodal units in the train, such a TETA may have different meanings. A TETA for an interchange point, for example, may be an estimated time of interchange (ETI) for some wagons or Intermodal units. For other wagons remaining in the train for further transportation by the same RU, the TETA might have no relevance. It is the task of the RU receiving the TETA information to identify and process that information, store it as a wagon movement in the Wagon and Intermodal Unit Operational Database and communicate it to the LRU, if the train is not running in Open Access mode. This is now considered in the following chapters.

4.2.7.2. ETI / ETA calculation

The ETI / ETA calculation is based on the information from the infrastructure manager in charge, which sends, within the Train Running Forecast message, the Train Estimated Time of Arrival (TETA) for defined reporting points (in any case for handover, interchange, or arrival points including Intermodal terminals) on the agreed train path e.g. for the handover point from one IM to the next IM (in this case TETA is equal to ETH).

For the interchange points or for other defined reporting points on the agreed train path, the RU must calculate for the next RU in the transport shipment chain, the estimated time of interchange (ETI) for the wagons and / or Intermodal units.

As an RU may have wagons with different journeys and from various LRUs within the train, the interchange point for the ETI calculation for the wagons may be different. This is explained in the following two simplified examples (The pictorial representation of these scenarios is given in Annex A index 5 chapter 1.4 and the sequence diagram based on example 1 for the interchange point C is shown in Annex A index 5 chapter 5).

Example 1: RU1 has wagon no. 1 and 2 from LRU1 and wagon no. 3 to 5 from LRU2 within the same train. At the interchange point C the further transport of the wagon 1 and 2 will be done by RU2 and for the wagon 3 to 5 by RU3. In this case RU1 must calculate related to the interchange point C the ETI for the wagon 1 and 2 and must send these values to LRU1. RU1 must also calculate related to the same interchange point C the ETI for the wagon 3 to 5 and send these values to LRU2.

Example 2: RU1 has wagon no. 1 and 2 from LRU1 and wagon no. 3 to 5 from LRU2 within the same train. At the interchange point C the further transport of the wagon 3 to 5 will be done by RU3 whereas the wagon 1 and 2 remain in the train of RU1 until the interchange point E, where the responsibility for these wagons will be changed to RU2. In this case RU1 must calculate related to the interchange point C only the ETI for the wagon 3 to 5 and must send these values to LRU2. For the wagons 1 and 2 the interchange point C is not relevant. The next relevant interchange point for these wagons is E and related to this point the RU1 must calculate the ETI and send these values to LRU1.

The next RU, based upon the ETI input of the preceding RU, calculates for its part the wagon related ETI for the next interchange point. These steps are effected by each succeeding RU. When the last RU (e.g. RU n) in the transport chain of a wagon receives the ETI from his preceding RU (e.g. RU n-1) for the interchange of the wagon between RU n-1 and RU n, the last RU (RU n) must calculate the estimated time of arrival of the wagons at the final destination. This is to cater for the placement of the wagons according to the wagon order and in line with the commitment of the LRU to his customer. This is the ETA for the Wagon and must be sent to the LRU. It must be electronically stored along with wagon movement. The LRU must grant access to the customer for his relevant data, according to contractual conditions.

Remark on Intermodal units: For the Intermodal units on a wagon, the wagon ETIs are also ETIs for the Intermodal units. Regarding the ETAs for Intermodal units it should be noticed, that the RU is not in the position to calculate such an ETA beyond the rail transportation part. Therefore the RU can only deliver ETIs related to the Intermodal terminal.

The Lead RU is responsible for the comparison of the ETA with the commitment to the customer.

Deviations of the ETA against the commitment to the customer must be handled in accordance with the contract and may lead to an alert

management process by the LRU. For the transmission of information on the result of this process is foreseen the Alert message.

As a basis for the Alert management process the LRU must have the possibility for a wagon related enquiry on deviations. This enquiry of an LRU and the response from an RU is also specified below.

4.2.7.3.Wagon ETI / ETA message

Purpose: Sending ETI or updated ETI from one RU to the next in the transport chain. The last RU in the transport chain of the wagons sends the ETA or updated ETA to the LRU.

Main data elements:

- RU identification which has produced the ETI or ETA,
- Departure or previous interchange station (ETI or departure time at origin station),
- Train number starting from departure or previous interchange station (from ETI or departure time at origin station),
- Actual departure date and Time of the train,
- Arrival or next interchange station (ETI/ETA end),
- Train number arriving at the ETI /ETA end station (Arrival or next interchange station),
- Arrival Date and Time of the wagon (ETI or ETA).

4.2.7.4.Alert message

Purpose: Following the comparison between ETA and commitment to the customer, the LRU may send an Alert message to the RUs involved.

Main data elements:

- Wagon number,
- Commitment to the customer: Arrival Date and hour,
- Actual ETA: Date and Time.

Remark: In case of Open Access the calculation of ETI and ETA is an RU internal process . In this case the RU is the lead RU itself.

4.2.7.5.Enquiry about wagon deviation messages

Purpose: LRU to enquire on the deviations to a specific wagon.

Enquiry: Main data elements:

- Wagon number,
- LRU identifier.

Response: Information data:

- *For each reporting point*

- Reporting location,
- Wagon reporting point status (departure, yard arrival, yard departure, interchange arrival, arrival at destination yard),
- Responsible RU at reporting location and according wagon reporting point status,
- Re-scheduled time (against current schedule if multiple reschedules),
- ETI, if Reporting point is an interchange point,
- Actual time at reporting point,
- *For each deviation at that reporting point...*
 - Reason code and delay time for this reason.

4.2.8. Wagon Movement

4.2.8.1. Preliminary Remarks

For the reporting of the movement of a wagon, the following data must be stored and electronically accessible. They must be also exchanged within message on contractual base to authorised parties. The detailed formats are defined in Annex A index 1.

- Wagon Release notice
- Wagon Departure notice
- Wagon Yard arrival
- Wagon Yard departure
- Wagon Exceptions message
- Wagon Arrival notice
- Wagon Delivery notice
- Wagon Delivery confirmation
- *Wagon Interchange reporting, will be described separately in chapter 4.2.9: Interchange Reporting*

4.2.8.2. Wagon Release Notice message

Purpose: LRU to RU: The Lead RU is not necessarily the first RU in the transport chain. In this case the LRU must tell the RU in charge that the wagon is ready for pull at the customer sidings (Place of departure according to the LRU commitment) at the given release time (date and time of departure).

This events must be stored in the Wagon and Intermodal Unit Operational Database.

Main data elements:

- Wagon number,
- Place, Date and Time of departure (Place from which a transport is scheduled to depart).

The following data must be easy accessible to RU and LRU as stored data in databases:

- Transportation unit, identification, size and type,
- Unit capacity used,
- Total weight (Booked/actual total weight (mass) of goods, including packing and carrier's equipment),
- Dangerous goods indication.

4.2.8.3. Wagon Departure Notice message

Purpose: RU to LRU: The RU must inform the LRU of the actual Date and Time that the wagon has been pulled from the place of departure.

This events must be stored in the Wagon and Intermodal Unit Operational Database. With this message exchange the responsibility for the wagon changes from customer to the RU.

Main data elements:

- Wagon number,
- Place, Date and Time of departure (Place from which a transport is scheduled to depart).

The following data must be easy accessible to RU and LRU as stored data in databases:

- Transportation unit, identification, size and type,
- Unit capacity used,
- Total weight (Booked/actual total weight (mass) of goods, including packing and carrier's equipment),
- Dangerous goods indication.

4.2.8.4.Wagon Yard Arrival message

Purpose: The RU must inform the LRU, that the wagon has arrived at its yard. This message can be based on a “Train running information” message from chapter 4.2.4 (Train Running Forecast). This event must be stored in the Wagon and Intermodal Unit Operational Database.

Main data elements:

- Wagon number,
- Yard of arrival identification,
- Date and Time of arrival at the yard.

4.2.8.5.Wagon Yard Departure message

Purpose: The RU must inform the LRU, that the wagon has left its yard. This message can be based on a “Train running information” message from chapter 4.2.4 (Train Running Forecast). This event must be stored in the Wagon and Intermodal Unit Operational Database.

Main data elements:

- Wagon number,
- Yard of departure identification,
- Date and Time of departure from the yard.

4.2.8.6.Wagon Exception message

Purpose: The RU must inform the LRU if something unexpected occurs to the wagon, which might have an impact for the ETI / ETA, or requires any additional action. This message requires in most of the cases also a new ETI / ETA calculation. If the LRU decided to have a new ETI / ETA, it sends a message back to the RU, which

has sent this message together with the indication “ETI/ETA requested” (message: Wagon Exception message New ETI / ETA Request). The new ETI / ETA calculation must follow the procedure of chapter 4.2.7 (Shipment ETI / ETA).

This information must be stored in the Wagon and Intermodal Unit Operational Database.

Main data elements:

- Wagon number,
- Place, Date and Time of disruption (Place where something unexpected happens during the transport),
- Reason / Disruption code.

In addition the following data must be easily accessible as stored data in databases:

- Transportation unit identification,
- Dangerous goods indication.

4.2.8.7. Wagon Exception message New ETI / ETA Request

Purpose: The LRU may send this message to the actual RU, which has sent the “Exception message”, to request for new ETI / ETA calculation. The LRU sends this message also to all following RUs to inform them about the deviations. The need for a new ETI / ETA calculation is up to the LRU and is not necessary in any cases.

Main data elements:

- Wagon number,
- Place, Date and Time of disruption (Place where something unexpected happens during the transport),
- Reason / Disruption code,
- New ETI / ETA request.

In addition the following data must be easy accessible as stored data in databases:

- Transportation unit identification,
- Dangerous good indication.

4.2.8.8. Wagon Arrival Notice message

Purpose: The last RU in a wagon or Intermodal unit transport chain must inform the LRU that the wagon has arrived at its yard (RU location).

Main data elements:

- Wagon number,
- Identification of Yard of the RU,
- Date and Time of arrival.

4.2.8.9. Wagon Delivery notice message

Purpose: The last RU in a wagon transport chain must inform the LRU that the wagon has been placed at the consignee's sidings.

Main data elements:

- Wagon number,
- Identification of placement on consignee sidings (location, zone, track, slot),
- Date and Time of placement.

The Wagon Delivery Notice may be sent a second time as a "Wagon Delivery Confirmation" with the additional data:

- Customer identifier.

Remark: In the case of Open Access the described wagon movement is an RU (LRU) internal process. Nevertheless all calculations and data storage must be effected by it as the LRU having a contract with and a commitment to the customer.

The sequence diagram for these messages based on example 1 for the ETI calculation for the wagons 1 and 2 (see chapter 4.2.7.2 ETI / ETA calculation) is integrated in the diagram for interchange reporting in Annex A index 5 chapter 6.

4.2.9. *Interchange Reporting*

4.2.9.1. Preliminary remark

The interchange reporting describes the messages attached to the transfer of responsibility for a wagon between two railway undertakings, which occurs at interchange points. It also commands the new RU to make an ETI calculation and to follow the process as described in chapter 4.2.7 (Shipment ETI / ETA).

The following messages must be exchanged:

- Wagon Interchange Notice,
- Wagon Interchange Notice / Sub,
- Wagon Received At Interchange,
- Wagon Refused At Interchange.

The information data of these messages must be stored in the Wagon and Intermodal Unit Operational Database. In case of any deviation a new ETI / ETA must be generated and communicated according to the process described in chapter 4.2.7: Shipment ETI / ETA. The sequence diagram for these messages is shown in connection with the wagon movement messages in Annex A index 5 chapter 6.

The wagon interchange notices and the wagon interchange notices / sub as well as the wagon received messages may be transferred as a list for various wagons, especially if these wagons are all within one train. In this case all the wagons may be listed within one message transfer.

In the case of Open Access there are no interchange points. At a handling point the responsibility for the wagons does not change. Therefore there is no special message exchange needed. But derived from the Running Information of the train at this reporting point, the wagon or Intermodal unit related information - regarding location and date / time of arrival and departure - must be processed and stored in the Wagon and Intermodal Unit Operational Database.

The contents of these messages are given as follows:

4.2.9.2. Wagon Interchange Notice message

Purpose: With the “Wagon Interchange Notice” a railway undertaking (RU 1) asks the next railway undertaking (RU 2) in the transport chain whether it accepts the responsibility for a wagon. With the “Wagon Interchange Notice / Sub” the RU 2 informs its IM, that it has accepted the responsibility.

Main data elements:

- Wagon number,
- Train number (only if the wagon is in a train),
- Location; date and time of interchange.

In addition the following data must be easily accessible as stored data in databases:

- Transportation unit identification (number, size, type),
- Total weight (Booked/actual total weight (mass) of goods, including packing and carrier's equipment),
- Unit capacity used,
- Dangerous good details, ID.

4.2.9.3. Wagon Interchange Notice / Sub message

Purpose: With the “Wagon Interchange Notice / Sub” the RU 2 informs the IM, that it has taken over the responsibility of a particular wagon.

Main data elements:

- Wagon number,
- Train number (only if the wagon is in a train),
- Location; date and time of interchange.

In addition the following data must be easily accessible as stored data in databases:

- Dangerous goods details, identification.

4.2.9.4. Wagon Received At Interchange message

Purpose: With the “Wagon Received At Interchange” message the RU 2 informs RU 1 that it accepts the responsibility for the wagon.

Main data elements:

- Wagon number,
- Location; date and time of interchange.

4.2.9.5. Wagon Refused At Interchange message

Purpose: With the “Wagon Refused At Interchange” message the RU 2 informs RU 1 that it is not willing to take over the responsibility for the wagon.

Main data elements:

- Wagon number,
- Location; date and time of interchange,
- Reason code for the refuse,
- Further Description (optional).

4.2.10. Data Exchange for Quality Improvement

To be competitive the European Railway Industry must deliver higher service quality to its customers (see also Annex III, Article 2.7.1 to the Directive 2001/16/EC).

A measurement process is an essential post trip process to support quality improvements.

In addition to measuring the service quality delivered to the customer, LRUs, RUs and IMs must measure the quality of the service components that in total make up the product delivered to the customer.

The process involves the IMs and the RUs (especially if they are Lead RUs) selecting an individual quality parameter, a route or location and a measurement period in which actual results are to be measured against predetermined criteria and which normally have been set out in a contract.

The results of the measurement process must clearly show the achievement level against the target which has been agreed upon between the contracting parties.

The measurement reports must be able to access sufficient detail to allow an analysis to indicate the location and apparent cause of reductions in quality e.g. delays. Root cause analysis must then be carried out on repetitive, quality failures, so that corrective action can be determined by the contracting parties.

It is the obligation of an IM and an RU to provide data, participate in root cause analysis, also with third parties, and to implement any corrective action which has been agreed to.

The measurement process is a repetitive one.

To measure quality the already defined messages may be used as shown under the 6 headings, listed below:

1. LRU / Customer : Transit Time, ETA, Alert Resolution

In contracts between RUs acting as service integrators (LRU) and customers, commitments can be made (depending on the individual agreement) regarding transit time, ETA and alert resolution. The most relevant messages for this measurement of quality are:

- *Release Notice,*
- *Departure Notice,*
- *Delivery notice.*

2. LRU / Service providers : Transit and Handling Times, ETAs, ETIs , Reason Codes

In contracts between a Lead RU and other transport service providers commitments can be made concerning transit times (hours) with individual service providers as follows:

- Release cut off / Pull time to interchange delivery,
- Pick up to in gate,

- In gate to loading,
- Interchange receipt to interchange delivery,
- Interchange receipt to placement / constructive placement,
- Grounding to delivery.

The most relevant messages for this measurement of quality are:

- *Release Notice,*
- *Departure Notice,*
- *Yard Arrival,*
- *Yard Departure,*
- *Arrival Notice,*
- *Wagon Interchange Delivery,*
- *Wagon Interchange Receipt,*
- *Wagon Interchange Refused.*

3. RU / IM : Train Performance, Train ETA (TETA), ETH

In contracts between RUs and IMs, a punctuality level for train schedules at specified reporting points can be specified as can the accuracy of train ETAs and ETHs. The most relevant messages for this measurement of quality are:

- *Train Running Forecast,*
- *Train Running Information,*
- *Enquiry / Response about train delay / performance.*

4. RU / IM : Path Availability / Planned

In contracts between RUs and IMs path availability to run trains will be clearly described in terms of a range of times at specified points. Train specifications in terms of maximum length and gross weight, loading gauge etc., will also be covered in these contracts. This aspect will be addressed under item number 6 (IM / RU: Train composition quality).

The procedures and time frames for confirming the utilisation of a path, cancelling the use of a planned path and the extent to which a path can be used outside (early or late) the specified range of times will also be covered in these contracts. The most relevant messages for this measurement of quality are:

- *Path Cancelled,*
- *Path Not Available.*

5. RU / IM : Path Availability on short notice

When an RU wants to run a train outside the time limits established for a planned path; a path request on short notice must be sent to the IM(s) involved (as provided in the Directive 2001/14/EC).

Periodically the RU will compare the path request and the response data for producing reports as follows:

- Path request response time against framework agreement,
- Number of paths supplied within certain time periods, within the requested time,
- Number of rejected path requests.

The most relevant messages for this measurement of quality are:

- *Path Request,*
- *Path Details,*
- *Path Details Refused,*
- *Path Cancelled,*
- *Path Not Available.*

6. IM / RU : Train composition quality

When the train ready messages and / or train composition lists are sent by an RU to the IM(s) or to other RUs; they must comply with the train specifications contained within the applicable contract. For the checking of this compliance and therefore for the measurement of the train composition quality the most relevant messages are:

- *Train Composition,*
- *Train Not Suitable.*

4.2.11. The Main Reference Data

4.2.11.1. Preface

The Infrastructure Data (the Network Statements and the stored data in the Infrastructure Restriction Notice Database) and Rolling Stock Data (in the Rolling Stock Reference Databases and in the Wagon and Intermodal Unit Operational Database) are the most important data for the operation of freight trains on the European network. Both types of data together allow an assessment of the compatibility of the rolling stock with the infrastructure, help to avoid multiple data input, which increase especially the data quality, and they give a clear picture on all available installations and equipment at any time for fast decisions during the operation.

4.2.11.2. The Infrastructure Restriction Notice Databases

Each IM is responsible for the suitability of a path on his infrastructure and the RU is obliged to check the train characteristics against the values given in the path details of its contracted path.

Without prejudice to the conditions for the usage of a path in the Network Statements or to the responsibilities in case of any restrictions in the infrastructure explained in the TSI Operation and Traffic Management, the RU must know before preparing the train, whether there are any restrictions on the line segments or stations (nodes) affecting its train composition described in the path contract.

For this the IMs must install and fill-in Infrastructure Restriction Notice Databases. The structure of such a database is outlined in Annex A index 2. The entries of these databases are based on segments in line with the relevant Network Statements with the addition of restriction information. These databases must be accessible via the Common Interface (4.2.14.1: General Architecture and 4.2.14.7: Common Interface).

The RU is obliged to take into account all restrictions in the Infrastructure Restriction Notice Database affecting its train running until the pre-departure period. If nothing else is defined in a contract between the IM and RU, the pre-departure period starts one hour before the scheduled time of departure.

In the pre-departure period the IM must notify directly the RU of any relevant changes arising in the Infrastructure Restriction Notice Database.

4.2.11.3. The Rolling Stock Reference Databases

The keeper of a rolling stock is responsible for the storage of the rolling stock data within a Rolling Stock Reference Database.

The Information that must be included in the individual Rolling Stock Reference Databases is described in detail in Annex A index 2. They must contain all items for:

- Identification of rolling stock,
- Assessment of the compatibility with the infrastructure,
- Assessment of relevant loading characteristics,
- Brake relevant characteristics,
- Maintenance data,
- Environmental characteristics.

The Rolling Stock Reference Databases must allow easy access (a single common access provided via the common interface) to the technical data to minimise the volume of data transmitted for each operation. Contents of the Databases must be accessible, based on structured access rights depending on privilege to all Service Providers (IMs, RUs, Logistic providers and Fleet managers) in particular for purposes of fleet management and rolling stock maintenance.

The entries in the Rolling Stock Reference Database can be grouped as follows:

- Administrative data,
related to certification and registration items such as reference to the EC registration file, id of the notified body, etc.; this may include historical data related to ownership, rental, etc. The following steps have to be taken into account:
 - EC certification,
 - Registration in the “home” state,
 - Date put into service in the state of registration,
 - Registration in other countries for the use on their national network,
 - Safety certification for all Rolling Stock which does not comply with the Rolling Stock TSI.

The keeper is obliged to ensure that these data are available and the processes behind have been conducted.

- Design data,
which shall include all constitutive (physical) elements of the rolling stock, including characteristics related to the environment, and all information that is expected to remain valid throughout the life of the rolling stock - this part may contain a history of major modifications, major maintenance, overhaul, etc.

4.2.11.4. The Rolling Stock Operational Data

Beside the reference data for rolling stock, the data representing the actual status of the rolling stock is the most important data for operational purposes.

This data shall include temporary data, such as restrictions, current and projected maintenance actions, km and fault counters, etc.; and all data that could be considered as "status" (temporary speed restrictions, brake isolated, needs for repair and fault description, etc.).

For use of the operational rolling stock data three different entities must be considered taking into account the different parties responsible for rolling stock during transport operation:

- Railway Undertaking as Duty holder during its transport control,
- Keeper of rolling stock and
- User (Hirer) of rolling stock.

For all three different parties the operational rolling stock data must be accessible by the authorised user, down to his predefined authorised level, using the single key given by the wagon id (wagon number).

The operational rolling stock data is a part of the European wide Wagon and Intermodal Unit Operational Database as described in chapter 4.2.12.2 Other Databases.

4.2.12. Various Reference Files and Databases

4.2.12.1. Reference Files

For the operation of freight trains on the European network the following reference files must be available and accessible to all Service Providers (IMs, RUs, Logistic providers and Fleet managers). The data must represent the actual status at all times.

Locally stored and administrated:

- Reference File of the emergency services, correlated to type of hazardous goods.

Centrally stored and administrated:

- Reference File of the Coding for all IM', RUs, Service provider companies,
- Reference File of the Coding for Transport Customers,
- Reference File of the Coding of Locations (Primary, subsidiary and zone-track-spot),
- Reference File of the Coding for customer locations,
- Reference File of all existing train control systems,
- Reference File of Hazardous goods, UN and RID numbers,
- Reference File of all different locomotive types,
- Reference File of all CN and HS codes for goods,
- Reference File of all European maintenance workshops,
- Reference File of all European audit bodies,
- Reference File of all European licensed operators including respective list of national safety certificates granted.

The coding of IMs, RUs, Transport Organisations and companies and Transport Customers as well as of Locations (Primary, subsidiary,...) including customer locations are pending.

4.2.12.2. Other Databases

To allow for the tracking of train and wagon movements, the following databases, updated at each relevant event in real time, must be installed. Authorised entities such as keepers and fleet managers must have access to the data relevant to fulfil their functions, according to contractual conditions.

- Wagon and Intermodal Unit Operational Database,
- Trip plan for wagon / Intermodal unit.

These databases must be accessible via the Common Interface (4.2.14.1: General Architecture and 4.2.14.7: Common Interface).

Wagon and Intermodal unit Operational Database

The communication between the Lead RU and RUs in the co-operation mode is based on wagon and/or Intermodal unit numbers. Therefore an RU, which communicates with the IMs at train level, must break down this information into wagon and Intermodal unit related one. This wagon and Intermodal unit related information must be stored in the Wagon and Intermodal Unit Operational Database. The information on train movement leads to new entries / updates in the Wagon and Intermodal Unit Operational Database for customer information. The movement part for a wagon or Intermodal unit in the database is set up at the latest when receiving the release time for the wagons or Intermodal unit from the customer. This release time is the first movement entry for a wagon into the Wagon and Intermodal Unit Operational Database related to an actual transport journey. The messages for the wagon movement are defined in the chapters 4.2.8 (Wagon Movement) and 4.2.9 (Interchange Reporting). This database must be accessible via the Common Interface (4.2.14.1: General Architecture and 4.2.14.7: Common Interface).

The Wagon and Intermodal Unit Operational Database is the most important one for the tracking of wagons and therefore for the communication between the RUs involved and the Lead RU. This database shows the movement of a wagon and of an Intermodal unit from departure through to final delivery at customer sidings with ETIs and actual times at different locations until the final delivery time ETA. The database also shows the different status of the rolling stock such as:

- Status: loading of the rolling stock

This status is required for the information exchange between the RU and the IMs and to other railway undertakings involved in the transport journey.

- Status: loaded wagon on journey

This status is required for the information exchange between the IM and the RU, with other infrastructure managers and with other railway undertakings involved in the transport journey.

- Status: empty wagon on journey

This status is required for the information exchange between the IM and the RU, with other infrastructure managers and railway undertakings involved in the transport journey.

- Status: unloading of rolling stock

This status is required for the information exchange between the RU at destination and the Lead RU for the transport.

- Status: empty wagon under fleet management control

This status is required to get the information about availability of a vehicle of defined characteristics.

Wagon Trip Plan Databases

Trains normally carry wagons from various Customers. For each wagon the Lead RU (RU acting as Service Integrator) must establish and update a trip plan which corresponds to the train path at train level. New train paths for a train - e.g. in case of service interruptions - lead to revised trip plans for the wagons concerned. The creation time for the trip plan is the receipt of the consignment note from the customer.

The Wagon Trip Plans must be stored by each LRU in a database. These databases must be accessible via the Common Interface (4.2.14.1: General Architecture and 4.2.14.7: Common Interface).

Remark:

In addition to the mandatory databases mentioned above, at each IM side a train database may be installed.

This infrastructure manager train database corresponds to the movement part of the Wagon and Intermodal Unit Operational Database. The main data entry are the train related data of the train composition message from the RU. All train events result in an update of this train related database. An alternative storage possibility for these data is the path database (chapter 4.2.2: Path Request). These databases must be accessible via the Common Interface (4.2.14.1: General Architecture and 4.2.14.7: Common Interface).

4.2.12.3. Additional Requirements on the Databases

Under the following points are listed additional requirements which must be supported by the various databases.

These are:

1. Authentication
A database must support the authentication of users of the systems before they can gain access to the database.
2. Security
A database must support the security aspects in the meaning of controlling access to the database. The possible encryption of the database contents itself is not required.
3. Consistency
A database selected shall support the ACID principle (**A**tomicity, **C**onsistency, **I**solation, **D**urability).
4. Access Control
A database must allow access to the data to users or systems that have been granted permission. The access control shall be supported down to a single attribute of a data record. The database shall support configurable, role based access control for insertion, update or deletion of data records.
5. Tracing

A database must support logging all actions applied to the database to allow for tracing the detail of the data entry (Who, What, When did the contents change).

6. Lock strategy
A database must implement a locking strategy which allows access to the data even when other users are currently editing records.
7. Multiple Access
A database must support that data can be accessed simultaneously by several users and systems.
8. Reliability
The reliability of a database must support the required availability.
9. Availability
A database must have an availability on demand of at least 99,9 %.
10. Maintainability
A maintainability of the database must support the required availability.
11. Safety
Databases themselves are not safety related. Hence safety aspects are not relevant. This is not to be confused with the fact that the data - e.g. wrong or not actual data - may have impact on the safety operation of a train.
12. Compatibility
A database must support a data manipulation language that is widely accepted, such as SQL or XQL.
13. Import facility
A database shall provide a facility that allows the import of formatted data that can be used to fill the database instead of manual input.
14. Export facility
A database shall provide a facility that allows to export the contents of the complete database or its part as formatted data.
15. Mandatory Fields
A database must support mandatory fields that are required to be filled before the relevant record is accepted as input to the database.
16. Plausibility Checks
A database must support configurable plausibility checks before accepting the insertion, update or deletion of data records.
17. Response times
A database must have response times that allows users to insert, update or delete data records in a timely manner.
18. Performance aspects

A database shall support the queries necessary to allow the effective run of about 60.000 train runs per 24 hours. About 50% of these train runs are deemed to take place within two hours.

The number and kind of queries or updates per train are dependent on the overall process for planning and running a train.

19. Capacity aspects

A database shall support the storage of the relevant data for all freight wagons respectively the network. It shall be possible to extend the capacity by simple means (i.e. by adding more storage capacity and computers). The extension of the capacity shall not require replacement of the subsystem.

20. Historical data

A database shall support the management of historical data in the meaning of making of data available that has been already transferred into an archive.

21. Backup strategy

A backup strategy shall be in place to ensure that the complete database contents for up to a 24 hour period can be recovered.

22. Commercial aspects

A database system used shall be available commercially-off-the-shelf (COTS-product) or be available in the public domain (Open Source).

Remarks:

The above requirements must be handled by a standard Database Management System (DBMS).

The usage of the various databases is embedded into various work flows described here before. The general workflow is a request / response mechanism, where an interested party requests information from the database through the Common Interface (4.2.14.1: General Architecture and 4.2.14.7: Common Interface). The DBMS responds to this request either by providing the requested data or by responding that no data can be made available (no such data exists or access is refused due to access control).

4.2.13. Electronic Transmission of Documents

The description in chapter 4.2.14 (Networking & Communication) presents the communication network to be used for data exchange. This network and the described security handling allow any type of network transmission, such as email, file transfer (ftp, http), etc. The type to choose can then be decided upon by the parties involved in the information exchange, which means, that the electronic transmission of documents, for example, via ftp is given.

4.2.14. Networking & Communication

4.2.14.1. General Architecture

This subsystem will see, over time, the growth and interaction of a large and complex Telematic rail interoperability community with hundreds of participating actors (RUs, IMs, ...), which will compete and/or co-operate in serving the market's needs.

The Network & Communication infrastructure supporting such rail interoperability community will be based on a common **Information Exchange Architecture**, known and adopted by all participating actors.

The proposed **Information Exchange Architecture**:

- is designed to reconcile heterogeneous information models by semantically transforming the data that is exchanged between the systems and by reconciling the business process and application-level protocol differences;
- has minimum impact on the existing IT architectures implemented by every actor;
- safeguards IT investments made already.

The Information Exchange Architectures favours a mostly Peer-to-Peer type of interaction between all actors, while it guarantees the overall integrity and consistency of the rail interoperability community by providing a set of centralised services.

A Peer-to-Peer interaction model allows the best cost distribution between the different actors, based on actual usage and it will present, in general, lesser scalability problems. A pictorial representation on the general architecture is given in Annex A index 5 chapter 1.5.

4.2.14.2. Network

Networking in this case means the method and philosophy of communication and does not mean the physical network.

Rail interoperability is based on a common **Information Exchange Architecture**, known and adopted by all participants, thus encouraging and lowering barriers for new entrants, especially customers.

The security issue will therefore be addressed not by the network (VPN, tunnelling, ...), but by exchanging and managing inherently secure messages. A VPN network is therefore not required (the administration of a large VPN network will be complex and costly to manage), thus avoiding problems with responsibilities and ownership allocation. Tunnelling is not considered as a necessary means for achieving the appropriate security level.

In any case if some actors already have or want to implement various degrees of security on selected partitions of the network, they can do so.

Over the public Internet network it is possible to implement a hybrid Peer to Peer model with a *central repository* and a *common interface* at each actors' node.

The central repository is approached first to obtain meta-information, such as the identity of the peer (actor) on which some information is stored, or to verify security credentials. Afterwards, a Peer to Peer communication is performed between involved actors.

4.2.14.3. Protocols

Only protocols belonging to the full Internet Protocol suite must be used.

OSI Reference Model	Internet Protocol Suite		
Application	FTP, Telnet, SMTP, SNMP		NFS
Presentation			XDR
Session			RPC
Transport	TCP, UDP		
Network	Routing Protocols	IP	ICMP
	ARP, RARP		
Link	Not specified		
Physical			

4.2.14.4. Security

To achieve a high level of security, all messages must be self contained, which means that the information in the message is secured and the receiver can verify the authenticity of the message. This may be solved by using an encryption and signing scheme similar to email encryption. This makes it possible to use any type of network transmission, like email, file transfer (ftp, http), etc. The actual type to choose can then be decided upon by the parties involved in the information exchange.

4.2.14.5. Encryption

Either asymmetric encryption or a hybrid solution based on symmetric encryption with public key protection must be used, due to the fact that sharing a common secret key among many actors will fail at some point. A higher level of security is easier to achieve if every actor takes responsibility for its own pair of keys, even though a high level of integrity of the central repository (the key server) is required.

4.2.14.6. Central Repository

The Central Repository must be able to handle:

- metadata – structured data describing the content of messages,
- Public Key Infrastructure (PKI),
- Certification Authority (CA),
- directory (“phonebook”) – it contains all needed information about the participating actors for exchanging messages.

The management of the central repository should be under the responsibility of a non-commercial co-European organisation.

4.2.14.7. Common Interface

The Common Interface is mandatory for each actor in order to join the rail interoperability community.

The Common Interface has to be able to handle:

- message formatting of outgoing messages according to the metadata,
- signing and encryption of outgoing messages,
- addressing of the outgoing messages,
- authenticity verification of the incoming messages,
- decryption of incoming messages,
- conformity checks of incoming messages according to metadata,
- handling the single common access to various databases.

Each instance of the Common Interface will have access to all the data required according the TSI within each RU, IM, etc, whether the relevant Databases are central or individual (see also Annex A index 5 chapter 1.6).

Based on the results of authenticity verification of incoming messages, a minimum level of message acknowledgement can be implemented:

- i. positive send ACK,
- ii. negative send NACK.

The common interface uses the information in the central repository in order to manage the above tasks.

An actor may implement a local “mirror” of the central repository to shorten response times.

4.3. Functional and technical specifications of the interfaces

In light of the essential requirements in Chapter 3, the functional and technical specifications of the interfaces are as follows:

4.3.1. Interfaces with the TSI Infrastructure

The infrastructure subsystem includes traffic management, tracking, and navigation systems: technical installations for data processing and telecommunications intended for long-distance passenger services and freight services on the network in order to guarantee the safe and harmonious operation of the network and efficient traffic management.

The subsystem Telematic Applications for Freight uses the data required for operational purposes as given by the path contract, eventually updated in the restriction notice database, as provided by the IM. Thus no direct interface exists between this TSI and the TSI for infrastructure.

4.3.2. Interfaces with the TSI Control/Command and Signalling

The only connection to control command and signalling is via the

- Path contract, where within the line segment description the relevant information about usable command control and signalling equipment is given and
- various Rolling Stock Reference Databases, where the command control and signalling equipment of the rolling stock must be stored.

4.3.3. Interfaces with the rolling stock subsystem

The subsystem Telematic Applications for freight identifies the technical and operational data, which must be available for the rolling stock.

The rolling stock TSI specifies the characteristics of a wagon. If the characteristics changes for a wagon, this must be updated in the Rolling Stock Reference Databases within the normal maintenance process for the database. Thus no direct interface exists between this TSI and the TSI for rolling stock.

4.3.4. Interfaces with the TSI operation and traffic management

The subsystem Operation and Traffic Management specifies the procedures and related equipment enabling a coherent operation of the different structural subsystems, both during normal and degraded operation, including in particular train driving, traffic planning and management.

The subsystem Telematic Applications for Freight mainly specifies applications for freight services including real-time monitoring of freight and trains and the management of connections with other modes of transport.

In order to ensure consistency between both TSIs, the following procedure applies.

When the specifications of the TSI Operation and Traffic Management related to the requirements of this TSI will be written and / or will become subject to amendments, then the body in charge of this TSI must be consulted.

In the case that the specifications of this TSI related to operational requirements specified in the TSI Operation and Traffic Management should be subject to any amendment, the body in charge of the TSI Operation and Traffic Management must be consulted.

4.4. Operating rules

In light of the essential requirements in Chapter 3, the operating rules specific to the subsystem concerned by this TSI are as follows:

4.4.1. Data quality

For data quality assurance purposes, the originator of any TSI message will be responsible for the correctness of the data content of the message at the time when the message is sent. Where the source data for data quality assurance purposes is available from the databases provided as part of the TSI, the data contained within those databases must be used for data quality assurance.

Where the source data for data quality assurance purposes is not provided from the databases provided as part of this TSI, the originator of the message must make the data quality assurance check from their own resources.

Data quality assurance will include comparison with data from databases provided as part of this TSI as described above plus, where applicable, logic checks to assure the timeliness and continuity of data and messages.

Data are of high quality if they are fit for their intended uses, which means they

- Are Error free: accessible, accurate, timely, complete, consistent with other sources, etc., and
- Possess desired features: relevant, comprehensive, proper level of detail, easy-to-read, easy-to-interpret, etc.

The data quality is mainly characterised by:

- Accuracy,
- Completeness,
- Consistency,
- Timeliness.

Accuracy:

The information (data) required needs to be captured as economically as possible. This is only feasible if the primary data, which plays a decisive role in the forwarding of a consignment, a wagon or a container, is only recorded,

if possible, on one single occasion for the whole transport. Therefore the primary data should be introduced into the system as close as possible to its source, e.g. on the basis of the consignment note drawn up when a wagon or a consignment is tendered for carriage, so that it can be fully integrated into any later processing operation.

Completeness:

Before sending out messages the completeness and syntax must be checked using the metadata. This also avoids unnecessary information traffic on the network.

All incoming messages must also be checked for completeness using the metadata.

Consistency:

Business rules must be implemented in order to guarantee consistency. Double entry should be avoided and the owner of the data should be clearly identified.

The type of implementation of these business rules depends on the complexity of the rule. For simple rules, database constraints and triggers are sufficient. In case of more complex rules which require data from various tables, validation procedures must be implemented which check the consistency of the data version before interface data are generated and the new data version becomes operational. It must be guaranteed that transferred data are validated against the defined business rules.

Timeliness:

The provision of information right in time is an important point. As far as the triggering for data storage or for message sending is event driven directly from the IT system the timeliness is not a problem if the system is designed in well manner according the needs of the business processes. But in most of the cases the initiation of sending a message is done by an operator or at least is based on additional input from an operator (for example the sending of the train composition or the actualising of train or wagon related data). To fulfil the timeliness requirements the updating of the data must be done as soon as possible also to guarantee, that the messages will have the actual data content when sending out automatically by the system.

In general the following requirements must be fulfilled:

The response time for enquiries must be less then 5 minutes. All data updates and exchanges must be done as soon as possible. The system reaction and transmission time for the update should be below 1 minute.

Data quality Metrics

For the completeness (Percent of data fields having values entered into them) of mandatory data and for the consistency of data (Percent of matching values across tables/files/records) a percentage of 100% must be reached.

For the Timeliness of data (Percent of data available within a specified threshold time frame) a percentage of 98% must be reached. As far as threshold values are not defined in this TSI, these value must be specified in the contracts between the involved parties.

The required accuracy (Percent of stored values that are correct when compared to the actual value) must be above 90%. The exact value and the criteria must been set out in the contracts between the involved parties.

4.4.2. Operating the central repository

The functions of the central repository are defined in chapter 4.2.14.6 (Central Repository). For data quality assurance purposes, the entity operating the central repository should be responsible for the updating and the quality of the metadata and the directory, and also for the administration of the access control (Public keys). Regarding the quality of the metadata a percentage of 100% must be reached for completeness, consistency, timeliness and accuracy.

4.5. Maintenance rules

In light of the essential requirements in Chapter 3, the maintenance rules specific to the subsystem concerned by this TSI are as follows:

The quality of the transport service must be guaranteed even if the data processing equipment were to break down in full or in part. It is therefore, advisable to install duplex systems or computers with a particularly high degree of reliability, and for which the uninterrupted operation during maintenance is ensured.

The maintenance aspects regarding the various databases are mentioned in chapter 4.2.12.3 (Additional Requirements on the Databases), points 10 and 21.

4.6. Professional qualifications

The professional qualifications of staff required for the operation and maintenance of the subsystem and for implementing the TSI are as follows:

The implementation of this TSI does not require a complete new system in hardware and software with new staff. The realisation of the requirements of the TSI leads only to changes, upgrades or functional enlargements of the operation as it is already done by the existing staff. Therefore, there are no additional requirements to the existing national and European rules on professional qualifications.

If necessary, an add-on training of staff should not just consist of showing them how to operate equipment. The member of staff must know and understand his specific role to be played in the overall transportation process. Staff must in particular be aware of the requirement to maintain a high working performance level, since this is a decisive factor for the reliability of the information to be processed at a subsequent stage.

The professional qualifications needed for the composition and operation of trains are defined in the TSI Operation and Traffic Management.

4.7. Health and safety conditions

The health and safety conditions of staff required for the operation and maintenance of the subsystem concerned (*or the technical scope as defined in paragraph 1.1*) and for the implementation of the TSI are as follows:

There are no additional requirements to existing national and European rules on health and safety.

4.8. Infrastructure and Rolling stock registers

In accordance with Article 24(1) of Directive 2001/16/EC, “the Member States shall ensure that registers of infrastructure and of rolling stock are published and updated annually. Those registers shall indicate the main feature of each subsystem or part subsystem involved and their correlation with the features laid down by the applicable TSIs. To that end, each TSI shall indicate precisely which information must be included in the registers of infrastructure and of rolling stock.”

Due to the annual update and publication of these registers they are not utilisable for the subsystem “Telematic Applications for Freight”. Therefore this TSI has nothing to indicate in these registers.

5. INTEROPERABILITY CONSTITUENTS

5.1. Definition

According to Article 2(d) of Directive 2001/16/EC:

Interoperability constituents are “any elementary component, group of components, subassembly or complete assembly of equipment incorporated or intended to be incorporated into a subsystem upon which the interoperability of the Trans-European conventional rail system depends directly or indirectly. The concept of a constituent covers both tangible objects and intangible objects such as software”.

5.2. List of Constituents

The interoperability constituents are covered by the relevant provisions of Directive 2001/16/EC.

There are no interoperability constituents determined as far as the subsystem Telematic Applications for Freight is concerned.

For the fulfilment of the requirements of this TSI only standard IT equipment is needed, without any specific aspects for interoperability in the railway environment. This is valid for hardware components and for the standard software used like operating system and databases. The application software is individual on each user's side and can be adapted and improved according the individual actual functionality and needs. The proposed “application integration architecture” assumes that applications might not have the same internal information model. Application integration is defined as the process of making independently designed application systems work together.

5.3. Constituents' Performances and Specifications

See chapter 5.2, not relevant for the TSI “Telematic Applications for Freight”.

6. ASSESSMENT OF CONFORMITY AND/OR SUITABILITY FOR USE OF THE CONSTITUENTS AND VERIFICATION OF THE SUBSYSTEM

6.1. Interoperability Constituents

6.1.1. Assessment Procedures

The assessment procedure for conformity or suitability for use of interoperability constituents must be based on European specifications or specifications approved in accordance with Directive 2001/16/EC.

In the case of suitability for use, these specifications will indicate all the parameters to be measured, monitored or observed, and will describe the related testing methods and measuring procedures, whether in a test-bench simulation or tests in a real railway environment.

Procedures for assessing conformity and/or suitability for use:

List of specifications, description of the testing methods:

Not relevant for the TSI Telematic Applications for Freight.

6.1.2. Module

At the request of the manufacturer or his representative established in the Community, the procedure is carried out by a notified body in accordance with the provisions of the pertinent modules of Council Decision 93/465/EEC as set out, amended and supplemented in the Annex to this TSI.

The modules should be combined and used selectively according to the particular constituent.

Not relevant for the TSI Telematic Applications for Freight.

6.2. Subsystem Telematic Applications for Freight

At the request of the awarding authority or its representative established in the Community, the notified body carries out EC verification in accordance with Annex VI to Directive 2001/16/EC.

According to Annex II of the Directive 2001/16/EC, the subsystems are broken down into structural and operational areas.

The conformity assessment is obligatory for TSIs in the structural area. The Subsystem Telematic Application for Freight belongs to the operational area and this TSI does not determine any modules for conformity assessment.

However the central repository and a common interface at each actor's node are the backbone of the application integration. The exchange information model is held in the centralised application integration repository, which holds the interface metadata in one physical location. The metadata contains information about the communication content (what is in the data being

sent), the touch point identities of the senders and receivers, and the interaction process mechanics application-level business protocols.

The following points are highlighted:

- The central repository contains the directory (phonebook) of all participating actors for the exchange of messages. This directory must represent the actual status at all times. Wrong entries become obvious immediately. No assessment procedure needed.
- The central repository also contains the certification authority (Open CA PKI). This is mainly an administration act, which is physically implemented. Wrong entries become obvious immediately. No assessment procedure needed.
- The central repository contains the message metadata (according to Annex A index 1) as the basis for message exchange in a heterogeneous information environment. The metadata must be administrated and updated in the central repository. Any incompatibility in the message structure or content of the messages for sending or receiving data will be recognised immediately and the transfer will be refused. No assessment procedure needed.
- The common interface at each actor's node contains mainly the local "mirror" of the central repository for shortening the response time and reducing the load on the repository. It must be ensured, that the data versions in the central repository and in the common interface are always the same. Therefore the data update must be done on the central level and new versions must be downloaded from there. No assessment procedure needed.

7. IMPLEMENTATION

7.1. Modalities of Application of this TSI

7.1.1. Introduction

This TSI is oriented to provide information support to the rail freight business process that can lead to a major enhancement of the quality of transportation services. As such its application is independent from the notions of new/upgrade or legacy infrastructure or rolling stock assets as it is usual in other TSI called for by Directive 2001/16.

Due to its pervasive nature the impact of this TSI will be profound on the business and operational processes of the whole of the European rail industry. Moreover, the continuous growth of international freight transport demands a European-wide information management perspective. These facts compound to call for the set-up of a coherent trans-European implementation plan for this TSI. This plan should provide both a vision of what is to be achieved when implementing the TSI and the way and timing to migrate from the present framework of fragmented information systems towards a comprehensive European-wide information highway that can provide value-added to all rail transport stakeholders – infrastructure managers, railway undertakings, freight forwarders and ultimately the client alike.

Set against this background the concept of a Strategic European Deployment Plan (SEDP) is mandated. The SEDP defines the target system that is to be achieved in order to implement this TSI together with its underpinning rollout plan as outlined in the following paragraph.

7.1.2. Strategic European Deployment Plan (SEDP)

7.1.2.1. Objectives of the SEDP

The purpose of the Strategic European Deployment Plan (SEDP) is three-fold:

1. To provide a vision for the implementation of the TAF TSI within the European Rail Industry;
2. To qualify such a vision from a technical and economic feasibility perspective;
3. To establish a roadmap of the activities deemed necessary in order to realise such a vision.

In addition to provide a roadmap for the implementation of the TAF TSI ensuring visibility of the whole implementation process, the SEDP should bestow appropriate yardsticks for the monitoring of its progress by the different stakeholders – viz. infrastructure managers, railway undertakings, freight forwarders and ultimately the client – in a way that can guarantee the defence of their best interests. This regards notably the required investments to be mobilised by the infrastructure managers and railway undertakings in

the potential upgrading and integration of their legacy IT systems and the capability of the TAF TSI-based systems in effectively responding to the ever evolving needs of information from freight forwarders and clients alike.

Set against this background, the SEDP should ultimately constitute an instrument enabling to focus the whole of the European railway industry on a pan-European information system development target, whilst allowing for the promotion of synergies, avoidance of fragmentation and the concentration of limited resources on those priority issues better responding to the overriding transportation service quality goals.

7.1.2.2. The SEDP Requirements

The elaboration of such a plan will require a systematic analysis of the relevant technical, operational, economic and institutional issues that underpin the implementation process of the TAF TSI. This includes in particular:

1. The inventory of the relevant legacy IT applications that could constitute the foundation on which to build a pan-European system capable of delivering the TAF TSI requirements (hereafter called *the TAF system*);
2. The definition of the functional and associated data and performance requirements necessary to deliver the TAF TSI;
3. The outline of *the TAF system* architecture. This shall be based on the analysis of the system configurations capable of potentially integrating the legacy IT facilities while delivering the required functionality and performance – e.g. centralised or distributed client-server architectures, agent-based architectures;
4. The establishment of the technical and interface requirements for the *TAF system* and its potential sub/client systems;
5. The elaboration of an overall *TAF system* development plan from concept-to-delivery. This should provide guidelines on the process and the planning for the potential integration of legacy facilities as well as a risk assessment of the crucial phases of such a plan. Moreover, it should account for the on-going and planned evolution of legacy facilities;
6. The identification of the appropriate governance structures underpinning the development of the *TAF system* as well as its operation throughout its lifetime;
7. An assessment of the total lifecycle costs (LCC) associated with the rollout and operation of the *TAF system* together with a subsequent investment plan.

Rather than following a sequential path this analysis should evolve through an iterative basis aimed at identifying the optimum system deployment

strategy. Such study cycle should conduce ultimately to the following specific outcome:

- A full set of functional, performance, system and technical specifications for the procurement of the *TAF system*;
- A rollout programme from concept-to-delivery. This shall include the detailed planning of all those project phases and major individual activities that concur to the achievement of the end goals;
- A definition of the governance structure, methods and procedures³ underpinning system development, validation and operation;
- An investment plan and a subsequent financial engineering approach enabling its realisation.

7.1.3. Modalities for Implementation

The modalities for application of this TSI are subject to the requirements of the Strategic European Deployment Plan (SEDP) as outlined previously.

For the purpose of the elaboration of the SEDP the following requirements do apply:

- Railway Undertakings and Infrastructure Managers shall contribute by providing functional and technical information about the existing individual telematics applications for freight⁴ ;
- The representative bodies from the railway sector acting on a European level as defined in Art. 3.2 of Regulation 881/2004/EC shall establish a Strategic European Deployment Plan as outlined in the previous paragraph. They shall forward this strategic plan to the Member States and the Commission not later than one year after the date of publication of this Regulation. If after this period of time no significant progress is observed the task will be embraced by the European Commission to subsequently propose draft legislation for the implementation of this TSI.
- Once the Strategic plan is completed, all activities related to the implementation of the subsystem Telematic Application for Freight have to be justified against this deployment plan. Any proposed non-adherence by a RU or IM should be justified in the implementation dossier submitted to the Member State, to the European Railway Agency and to the EC.

³ e.g. quality assurance standards, system development methodology, testing methodology, documentation planning.

⁴ Existing telematic applications for freight are telematic applications for freight that are already in service before this TSI enters into force

7.2. Migration Strategy

Migration strategies have to be devised in order to cater for the transition period between the current framework of differentiated information systems and the fulfilment of this TSI as commanded by the SEDP.

For this purpose the information handling concepts embodied in this TSI were developed in order to facilitate such a migration. They do allow for an incremental build-up of the target TAF TSI pan-European system, notably through facilities such as peer-to-peer communication based e.g. on the concept of aggregate data repositories (viz. including message metadata, data directory and certification authority).

An illustrative example how such information exchange between a RU and IM could work in practice is given below. The example shows only the logical inter-system communication dependencies structured in stepwise manner without accounting for any individual migration needs that might be required by the individual systems. These latter needs should be duly considered when drawing up the SEDP.

Step 1: The general architecture, as described in chapter 4.2.14.1 (General Architecture), embodies the concept of a “central repository” operated by a neutral and independent entity. At the site of each participant in the communication network, an interface layer, which may include a message broker, is specified for interoperability, which can be built centrally or individually. These parts are in respect of “networking and communication”, the only operational aspects required for interoperability. They are also the basic preconditions for the European wide data exchange. Therefore they must be realised and installed before any other function can come into operation.

After this step already the electronic transmission of documents (chapter 4.2.13: Electronic Transmission of Documents) may be realised independent from the logical sequence of the other steps.

Available Features after this step for	
<u>IM</u>	<u>RU</u>
The basis for the information exchange is given.	
Advantage:	
Electronic transmission of documents in the final environment is possible.	
Tests of the various further steps can be made in real environment.	

Step 2: At the same time or shortly after step 1, the Rolling Stock Reference Databases and the Wagon and Intermodal Unit Operational Database (chapter 4.2.11.3: The Rolling Stock Reference Databases and chapter 4.2.12.2: Other Databases) must be available. If not all data are already in the databases, it must be at least possible to put manually into the Wagon and Intermodal Unit Operational Database - for each wagon in a running train - the data needed for rail transport as listed in Annex A index 2).

Available Features after this step for	
IM	RU
<p>The basic information in the Wagon and Intermodal Unit Operational Database and the Rolling Stock Reference Databases are accessible. A manual update of the relevant data is possible.</p> <p>Advantage: The IT support for a path request and for the train composition is given. An easy access to the rolling stock data for third parties e.g. fleet managers can be realised.</p>	

Step 3: For outside access to the various databases the common interface must be realised and implemented in parallel or shortly after step 2.

Available Features after this step for	
IM	RU
<p>A database for the storage of path / train information is prepared.</p> <p>The data input can start manually The on-line connection to the existing IM systems for the automatic input and update is available.</p> <p>Advantage: Data of incoming messages can be stored as for the final version</p>	<p>The database(s) for the movement data of wagons / Intermodal units and for the load (weight, dangerous goods) is prepared, together with the reference files needed.</p> <p>From now on the relevant data from the delivered consignment notes (wagon order) and / or of the existing train composition can be filled in manually or already automatically via RU internal connection to the existing systems for recording the consignment notes and for recording the train composition.</p> <p>The check of the wagon data with the Rolling Stock Reference Databases is possible as well as the assessment of the train data with the infrastructure data.</p> <p>Advantage: Support for creating the train composition</p> <p>Data of incoming messages can be stored as for the final version</p>

For the next steps it is important to mention, that the proposed architecture allows for a smooth coming into operation of the various functions to fulfil the requirement of the subsystem Telematic Applications for Freight. Based on the central repository (message metadata, directory and certification authority), it is possible to enable the data exchange between two partners individually depending on message type.

Step 4: The Path request messages can be implemented independent from the next steps, but for step 6 it is necessary that the path is already named by a path number.

Available Features after this step for	
<u>IM</u>	<u>RU</u>
<p>Automatic data input into the database for the storage of path / train information. Telematic supported path definition in combination with the Infrastructure Restriction Notice Databases.</p> <p>Advantage: Faster reactions on path requests, better demand oriented path usage, higher reliability of the path characteristic data (current status in the Infrastructure Restriction Notice Databases), improvement in the use of the infrastructure.</p>	<p>Path request on short notice is possible</p> <p>Advantage: Better demand oriented path request is possible. Faster reaction by IM on path requests, A higher reliability of the path characteristic data. Speeds up wagon turn around times.</p>

Step 5: The Wagon orders data deliver basic information for the composition of a train, therefore these messages should go into operation before step 6.

Available Features after this step for	
<u>IM</u>	<u>RU</u>
<p>No additional features</p>	<p>Automatic take over of the consignment note data into the data storage of step 3. Automatic generation and sending of wagon orders to co-operating RUs.</p> <p>Advantage: Faster distribution of the wagon orders, shortened handling time at Interchange points.</p> <p>Support for applying international purchase /sales contracts.</p>

Step 6: The coming into operation of train preparation messages is the next step, whereby the sending of the train composition message is the most important one and should be realised first.

Available Features after this step for	
<u>IM</u>	<u>RU</u>
<p>Receiving train composition in advance. Higher reliability of the data. Clear time stamp of the start</p>	<p>Sending train composition mostly automatically generated, high reliability of the data, automatic update into the</p>

time for the use of the path. Automatic update of the database for the storage of path / train information.	data storage of step 3.
Advantage: Optimising of the path usage, Clear responsibility at start time.	Advantage: Clear responsibility at start time for the IM service, reliable start time for the wagons / shipments
	Support for minimising expenses and costs by reduced data capture at borders
	Support for speeding up shipment times by guaranteed take-over of trains by RU and IM
	Support for minimising risks during take over of wagons

Step 7: At latest before step 8, the wagon movement functions “Wagon Release and Departure notice, Wagon Yard arrival, Wagon Yard departure, Wagon Arrival notice and wagon delivery notice / confirmation” together with the trip planning functionality should be realised at the RU level.

Available Features after this step for	
IM	RU
No additional features	IT supported trip planning at wagon and Intermodal unit level is possible.
	The System is prepared to calculate send and receive wagon and Intermodal unit related movement messages.
	Advantage: First step for the tracking and tracing of wagons and shipments at an international level.

Step 8: For the next step the Train running and Train running forecast messages should be realised. With the Train running forecast message, the “train estimated time of arrival (TETA respectively ETH) can be sent, which is the basis for the calculation of the wagon / shipment related ETIs and the ETA. This step also contains the realisation of the enquiry / response for Train running and Train forecast.

Available Features after this step for	
IM	RU
Train running and train running forecast in real time sent to neighbour IMs and to the RUs	Location and train estimated time as a basis for wagon / shipment related ETI / ETA calculation available.
Advantage: Enhanced and more reliable planning opportunities supporting	Advantage: Tool to meet customer’s wish to be

efficient path usage.	informed if transport problems occur.
Reduces border stops, supports demand oriented path usage.	Together with the finalising of step 4 support for minimising expenses and costs by demand oriented path usage.
	Enhanced and more reliable planning opportunities.
	Support for speeding up shipment times by reducing border stops.
	Support for minimising risks during take over of trains.

Step 9: The interchange reporting (chapter 4.2.9: Interchange Reporting) and the functionality of chapter 4.2.7 (Shipment ETI / ETA) should be implemented at the same time or shortly after Step 8. This is in particular relevant for RUs.

Available Features after this step for	
<u>IM</u>	<u>RU</u>
Knowing the location of a wagon within the IM's infrastructure, and which RU is responsible, even if the wagon is not in a train.	ETI and ETA calculation based on TETA values, automatic update of the movement data in the Wagon and Intermodal Unit Operational Database.
Advantage: Knowing wagon location and responsible entity in a yard.	International empty wagon management fully realised.
	International trip planning completed.
	Advantage: Shipment tracking and tracing on an international level.
	Speeding up wagon turn around times.
	Support for International empty wagon management.
	Support for consignments abroad and booking of services offered.
	Support for quality improvement of international transports.
	Support for international Trip planning.

Step 10: The realisation of the "service disruption information" functionality is part of step 10, together with the realisation of the enquiry / response about train delay, train identifier and train at reporting location. Based on the disruption information, the wagon exception message at RU level (chapter 4.2.8.6: Wagon Exception message and chapter 4.2.8.7: Wagon Exception message New ETI / ETA Request) could come into operation.

Available Features after this step for
--

IM	RU
Disruption handling and delivery outstanding reports for RUs.	Exception handling and outstanding enquiries.
Advantage: Quality improvement of the service	Advantage: International shipment tracking and tracing. Speeding up wagon turn around times.

Step 11: After a consolidation phase, the evaluation of the transmitted and stored data for quality improvement could come into operation.

Available Features after this step for	
IM	RU
Availability of exhaustive statistical database	
Advantage: Provision of input data for improvement of the transport service quality	

7.3. Management of Change

7.3.1. Introduction

Change is a facet inherent to any kind of computer-based systems used in real-world environments. It is prompted by the emergence of new requirements or by changes to existing requirements either due to errors reported in operation or the need of improvements in performance or other non-functional characteristics.

But change has to be managed as it is underpinned by continuity of service considerations and by backward compatibility objectives so as to provoke minimal time and cost overheads to the operation of already deployed IT equipment providing TAF functionality (i.e. legacy IT facilities). It is therefore crucial to define a clear strategy of how to implement and manage change to legacy IT equipment to avoid disruption to railway operations without undermining the underlying objectives of guaranteeing continuity of service and interoperability. Two main issues underpin the definition of such a strategy:

- the establishment of a Configuration Management framework defining the standards and procedures for managing system evolution. This should include how to record and process proposed system changes, how to relate these changes to system components and how to track system releases;
- a policy for release of system baselines.

7.3.2. Baselineing

System stability is essential so that actual implementation and deployment can be realistic. This need for stability is akin to all parties:

- the infrastructure managers and the railway operators that will have to handle various versions of systems providing TAF functionality;
- the industry that needs time to specify, develop and prove continued interoperability.

A baseline in essence embodies the concept of a stable kernel in terms of system functionality, performance and other non-functional characteristics (e.g. RAM)⁵. However, past experience with this type of systems has shown that a number of version releases⁶ are needed to achieve a stable and implementation-suitable baseline. This can be illustrated as a cascade process as follows:

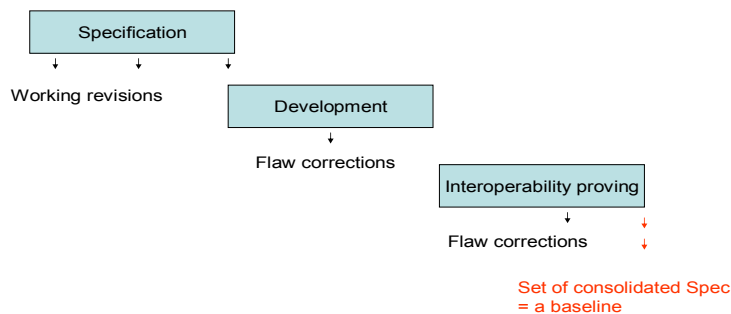

Through its feedback loops, such a process is highly intertwined. This precludes putting several of those processes in parallel, an approach that would lead to unstable, confusing and operationally hampering situations. Baselines have then to be processed in a series rather than in a parallel manner as illustrated below:

⁵ A baseline acts as a reference starting point for a controlled management of the system evolution.

⁶ A version release is a version of the system that is distributed to railway customers. Versions of the system may have different functionality, performance or may repair system faults or safety or security shortcomings.

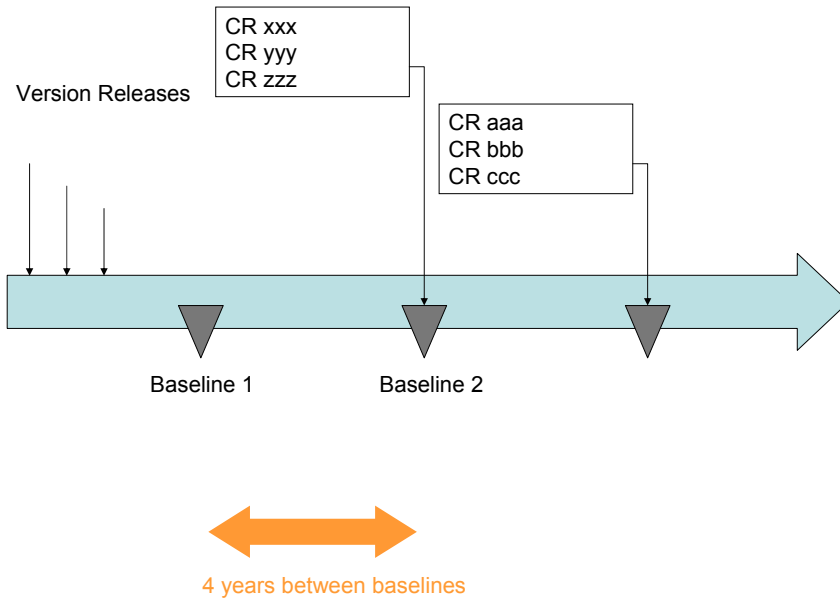

7.3.3. *Baseline release*

Based on current experience the timing between different baselines can be estimated to be circa four to five years.

A new baseline should in principle be linked with significant modifications of the system functionality or system performance. This could include aspects such as:

- the incorporation of set of today's national functions, where these can be generalized, within the interoperable kernel;
- other future value-added services.

Each baseline should also embrace the functionality of the previous baseline. Debugging versions to repair system faults or security shortcomings should be handled as a version release of a particular baseline. Unless prevented by security implications such version releases within the same baseline are to be backward compatible.

The added functionality that might be embodied in different baselines necessarily implies that different baselines are not backward compatible. However, in order to facilitate migration and in the extent possible from a technical view point, different baselines should encompass a common core of functionality for which backward compatibility should be ensured. Such a common core should provide a minimum kernel to enable interoperable data services under acceptable performance.

7.3.4. *Deployment of new baselines*

Infrastructure managers and railway operators will never be in a position to switch from one baseline to the next over night. Henceforth, each baseline has to developed hand-in-hand with an appropriate migration strategy. This is to address problems such as co-existence of TAF facilities compliant with different versions of the TAF specifications, preferred paths of migration (viz. trackside priority, rolling-stock priority or simultaneous) as well as the indicative timeframes and the priorities for the migration.

7.3.5. *Change Management Process – the requirements*

As mentioned earlier, change is a fact of life for large software based systems. Henceforth, change management procedures should be designed to ensure that the costs and benefits of change are properly analyzed and that changes are implemented in a controlled way. This requires the defined change management process and associated tools to ensure that changes are recorded and applied to the specifications in a cost-effective manner. Whatever the specific details of such a process might eventually be, the latter should be broadly mapped on a structured approach as follows:

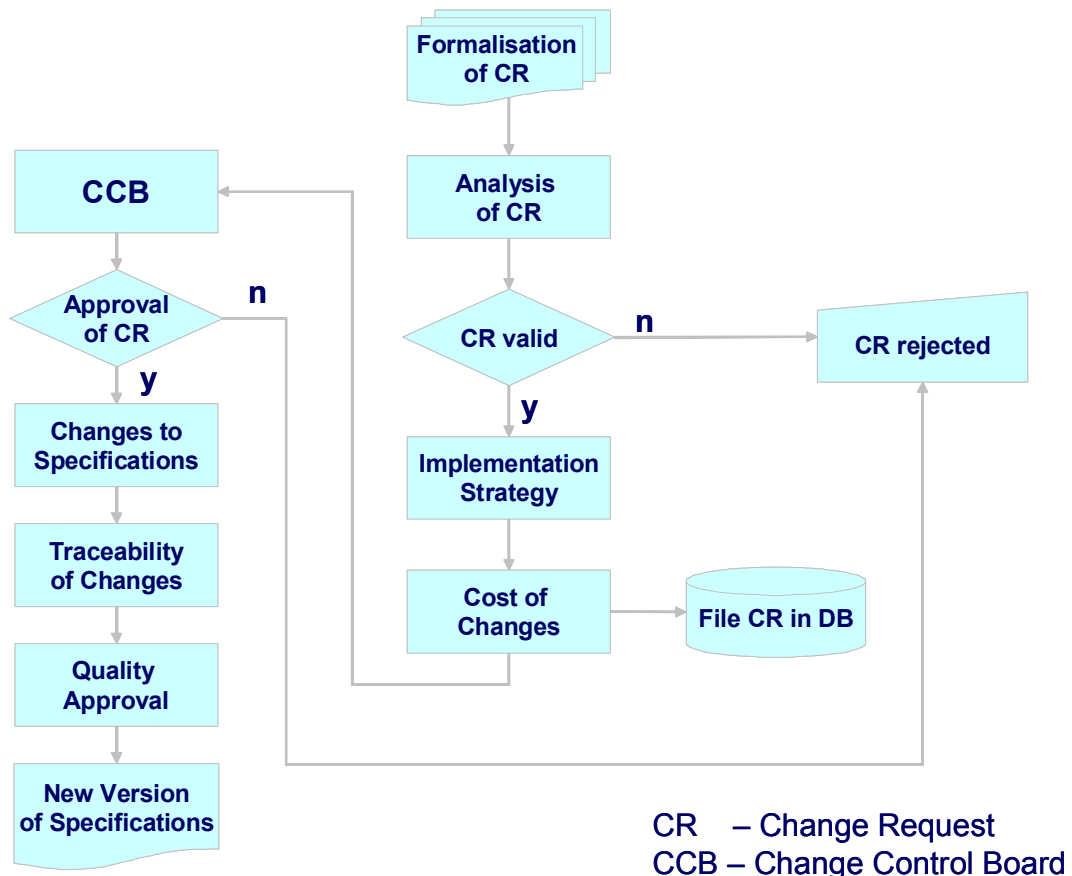

A configuration management plan embodying the set of standards and procedures for change management should underpin the whole of the change management process as described above. The generic requirements for such a plan are described in paragraph 06 below. The implementation strategy for the approved changes should be formalised (on the basis of due process and due documentation) into a change management plan that includes notably:

- the identification of the **technical constraints** underpinning the change;
- a statement of who takes **responsibility** for the change implementation procedures;
- the **validation** procedure for the changes to be implemented;
- the **policy** for change management, release, migration and roll-out.

An important part of the change management process is the definition of the responsibilities for the delivery of the specifications and for both its quality assurance and configuration management. It is planned that most of these tasks will revert to or will be supervised by the European Railway Agency (established by the EC Regulation 881/2004) when this will begin operation. The change management process should be formalised within the set of documentation referred to in Annex A.

Finally, it is essential that the Change Control Board (CCB), which eventually will act as overall system authority, is composed of a representative cross-section of the all interested parties – viz. infrastructure managers, railway undertakings, supply industry, notified bodies and regulatory authorities alike. Such affiliation of the parties should ensure a system perspective on the changes that are to be made and a global assessment of their implications. The CCB ultimately will be put under the aegis of the European Railway Agency.

7.3.6. Configuration Management Plan – the requirements

The configuration management plan should describe the set of standards and procedures for change management encompassing notably:

- the definition of what **entities** are to be managed and a formal scheme for identifying these entities;
- a statement of who takes **responsibility** for the configuration management procedures and for submitting controlled entities to the configuration management decision structure;

- the **configuration management** policies that are to be used for change control and version management;
- a description of the **records** of the configuration management process which should be maintained;
- a description of the **tools** to be used for configuration management and the process to be applied when using these tools;
- a definition of the **configuration database** which will be used to record configuration information.

The specific details of the Configuration Management processes are to be formalised through specifications to be incorporated in the list of specifications included under Annex A to this TSI.

7.4. Specific cases

7.4.1. Introduction

The following special provisions are permitted in the specific cases below.

These specific cases belong to two categories: the provisions apply either permanently (case "**P**"), or temporarily (case "**T**"). In temporary cases it is recommended that the Member States concerned should conform with the relevant subsystem either by 2010 (case "**T1**"), an objective set out in Decision No 1692/96/EC of the European Parliament and of the Council of 23 July 1996 on Community guidelines for the development of the Trans-European transport network, or by 2020 (case "**T2**"). "T open" is defined as an undetermined period, which will be fixed in a future revision of this TSI.

7.4.2. List of specific cases

7.4.2.1. Specific case for EU member states with border to third countries

On the territories of EU Member States having a border with third countries, the requirements of this TSI are not obligatory to transports directly arriving from or going to these third countries (case "T open").

However if the transport journey will be extended to another EU Member State, then the requirements of this TSI must be applied in full, provided that there is not a bilateral or multilateral agreement between the States concerned or between RUs or IMs acting in the territory of those Member States

7.4.2.2. Specific case for Greece

For a transport journey operated on lines with 1000 mm track gauge, national rules shall apply.

ANNEX A: LIST OF ACCOMPANYING DOCUMENTS**LIST OF MANDATORY SPECIFICATIONS**

Index N	Reference	Document Name	Version
1	AEIF_TAF_MesData_V11_041021.doc	CR Telematic Applications for freight: Data Definitions and Messages	1.1
2	AEIF_TAF_DbsData_V10_040322.doc	CR Telematic Applications for freight: The Infrastructure Data and the Rolling Stock Data	1.0
3	AEIF_TAF_ConData_V10_040622.doc	CR Telematic Applications for freight: The Consignment Note Data and Description	1.0
4	AEIF_TAF_Patdata_V10_040622.doc	CR Telematic Applications for freight: The Train Path Data and Description	1.0
5	AEIF_TAF_FigSeq_V10_040622.doc	CR Telematic Applications for freight: Figures and Sequence Diagrams of the TAF TSI Messages	1.0
6	AEIF_TAF_CofMgt_V10_041012.doc Pending	TAF Configuration Management, Concept and Generic Requirements	1.0

ANNEX B: GLOSSARY

Term	Description
<p>ACID</p>	<p>Atomicity, Consistence, Isolation, Durability</p> <p>These are the four primary attributes ensured to any transaction:</p> <p>Atomicity. In a transaction involving two or more discrete pieces of information, either all of the pieces are committed or none are.</p> <p>Consistency. A transaction either creates a new and valid state of data, or, if any failure occurs, returns all data to its state before the transaction was started.</p> <p>Isolation. A transaction in process and not yet committed must remain isolated from any other transaction.</p> <p>Durability. Committed data is saved by the system such that, even in the event of a failure and system restart, the data is available in its correct state.</p> <p>The ACID concept is described in ISO/IEC 10026-1:1992 Section 4. Each of these attributes can be measured against a benchmark. In general, however, a transaction manager or monitor is designed to realise the ACID concept. In a distributed system, one way to achieve ACID is to use a two-phase commit (2PC), which ensures that all involved sites must commit to transaction completion or none do, and the transaction is rolled back.</p>
<p>AEIF</p>	<p>Association Européenne pour l'Interopérabilité Ferroviaire. AEIF is according directive 2001/16/EC the "joint representative body, the common association of UIC, UNIFE and UITP.</p>
<p>Applicant</p>	<p>means a licensed railway undertaking and/or an international grouping of railway undertakings, and, in Member States which provide for such a possibility, other persons and/or legal entities with public service or commercial interest in procuring infrastructure capacity, such as public authorities under Regulation (EEC) No 1191/69 (5) and shippers, freight forwarders and combined transport operators, for the operation of railway service on their respective territories.</p>
<p>Block train</p>	<p>A specific form of a direct train with only as much wagons as needed, running between two transhipment points without intermediate marshalling.</p>

Term	Description
Booking	The process of making a reservation for space on a means of transport for the movement of goods.
CA	Certification Authority
CN-code	8 digit Code list for products used by customs.
Combined rail transport	Intermodal transport where the major part of the European journey is by rail by any initial and/or final leg carried out by road are short as possible.
Consignee	Party by whom the goods are to be received. Synonym: Goods receiver
Consignment	A separately identifiable amount of goods to be transported from one consignor to one consignee via one or more than one modes of transport as specified in one single transport document (Synonym: shipment).
Consignment note	A document which evidence a contract for the transportation by a carrier of one consignment from a named place of acceptance to a named place of delivery. It contains details of the consignment to be carried.
Consignor	Party which, by contract with a Service Integrator, consigns or sends goods with the carrier, or has them conveyed by him. Synonyms: Shipper, Goods sender.
Co-operation mode	Mode of train operation where various RU co-operate under the leadership of one RU (LRU). Each involved RU contracts the needed path for the transport journey on its own.
COTS-product	Commercially off the shelf products
Departure date/time, actual	Date (and time) of departure of means of transport.
Direct train	A train with related wagons which runs between two transshipment points (initial source – final destination) without intermediate marshalling.
Duty holder	Any individual or legal entity responsible for the risk which he imports onto the network, i.e. the RU.
Encryption	Encoding of messages Decryption: converting encrypted data back into original form
Essential requirements	Essential requirements means all the conditions set out in Annex III of the Directive 2001/16/EC which must be met by the Trans-European conventional rail system, the subsystems, and the interoperability constituents including interfaces.

Term	Description
ETA	Estimated Time of Arrival of wagons at the customer side.
ETH	Estimated Time of Handover of a train from one IM to another.
ETI	Estimated Time of Interchange of wagons from one RU to another.
Forecast Time	Best estimate of arrival, departure or passing time of a train.
FTP	File Transfer Protocol A protocol to transfer files between computer systems in the network TCP/IP.
Gateway	Station within the journey of a train with Intermodal units, where the load changes the wagons.
GGP	Gateway to Gateway Protocol See also IP
Gross weight of load	Booked/actual total weight (mass) of goods, including packing but excluding the carrier's equipment.
Handling point	Station where the RU may change the train composition, but where it remains responsible for the wagons, no change of responsibility.
Handover point	Point where the responsibility changes from one IM to another.
Haulage	Transport by road
Hirer	Any individual or other legal entity designated as such by the keeper / owner of a wagon.
HS code	6 digit Code list for products used by customs, identically to the first 6 digits of the CN Code.
HTTP	Hypertext Transfer Protocol The client / sever protocol used on connect to servers on the Web.
ICMP	Internet Control Message Protocol (ICMP) Occasionally a gateway (see GGP) or destination host (see IP) will communicate with a source host, for example, to report an error in datagram processing. For such purposes this protocol, the Internet Control Message Protocol (ICMP), is used. ICMP, uses the basic support of IP as if it were a higher level protocol, however, ICMP is actually an integral part of IP, and must be implemented by every IP module. ICMP

Term	Description
	<p>messages are sent in several situations: for example, when a datagram cannot reach its destination, when the gateway does not have the buffering capacity to forward a datagram, and when the gateway can direct the host to send traffic on a shorter route. The Internet Protocol is not designed to be absolutely reliable. The purpose of these control messages is to provide feedback about problems in the communication environment, not to make IP reliable. There are still no guarantees that a datagram will be delivered or a control message will be returned. Some datagrams may still be undelivered without any report of their loss. The higher level protocols that use IP must implement their own reliability procedures if reliable communication is required. The ICMP messages typically report errors in the processing of datagrams. To avoid the infinite regress of messages about messages etc., no ICMP messages are sent about ICMP messages. Also ICMP messages are only sent about errors in handling fragment zero of fragmented datagrams. (Fragment zero has the fragment offset equal zero).</p>
IM	<p>Infrastructure Manager: Any body or undertaking that is responsible in particular for establishing and maintaining railway infrastructure. This may also include the management of infrastructure control and safety systems. The functions of the infrastructure manager on a corridor or part of a corridor may be allocated to different bodies or undertakings (Directive 2001/14/EC).</p>
Infrastructure manager (IM)	See IM
Interchange	<p>The Transfer of control from one railway company to another for practical operational and safety reasons. Examples are:</p> <ul style="list-style-type: none"> ▪ Mixed services, ▪ Services with shared haulage responsibility, ▪ The transfer of information between different railway administrations, ▪ The transfer of information between wagon owners / keepers and train operators.
Interchange point	<p>Location where the transfer of responsibility for the wagons of a train goes from one RU to another RU.</p> <p>Regarding a train running, the train is taken over from one RU by the other RU, which owns now the path for the next journey section.</p>
Intermediate point	<p>Location which defines the start or end point of a journey section. This may be e. g. an interchange, handover or</p>

Term	Description
	handling point.
Intermodal operator	Operator of an Intermodal terminal, e.g. a Gateway.
Intermodal Service Integrator	Any body or undertaking, which has the contract with customers for the transport of Intermodal units. He is preparing waybills, managing capacity on block trains etc.
Intermodal terminal	Location which provides the space, equipment and operational environment under which the loading units (freight containers, swap bodies, semi-trailers or trailers) transfer takes place.
Intermodal transport	The movement of goods in one and the same loading unit or vehicle which uses successively several modes of transport without handling of the goods themselves in changing modes.
Intermodal Unit	A Load Unit which can be transported by different modes e.g. container, swap body, semi-trailer, trailer.
Internet	<ul style="list-style-type: none"> - Any large network made up of several smaller networks; - A group of networks that are interconnected so that they appear to be one continuous large network, and can be addressed seamlessly at the OSI model Network Layer through routers; - The industry name for the network, used as reference resource for e-mail and an on-line chat room for users around the world.
Interoperability constituent	means any elementary component, group of components, subassembly or complete assembly of equipment incorporated or intended to be incorporated into a subsystem upon which the interoperability of the Trans-European conventional rail system depends directly or indirectly. The concept of a constituent covers both tangible objects and intangible objects such as software.
IP	<p>The Internet Protocol</p> <p>The Internet Protocol (IP) is used for host-to-host datagram service in a system of interconnected networks.</p> <p>The network connecting devices are called Gateways. These gateways communicate between themselves for control purposes via a Gateway to Gateway Protocol (GGP).</p>
Journey	A “journey” denotes the spatial forwarding of a loaded or empty wagon from the forwarding station to the destination station.
Journey section	Is the part of the journey which takes place on one

Term	Description
	<p>infrastructure sector of an infrastructure manager or</p> <p>Part of the journey from the entry handover point to the exit handover point of the infrastructure of one infrastructure manager.</p>
Keeper	<p>The person, who being the owner or having the right to dispose of it, exploits a vehicle economically in a permanent manner as a means of transport and is registered as such in the Rolling Stock Register.</p>
Lead Railway Undertaking	<p>Responsible RU, which organises and manages the transport line according to the customer's commitment. It is the single point of contact for the customer. If more than one Railway Undertaking is involved in the transport chain, the LRU is responsible for the co-ordination of the various Railway Undertakings. A customer may be especially for Intermodal transport an Intermodal service integrator.</p>
Loco ID	<p>Unique identification number of a traction unit</p>
LRU	<p>See Lead Railway Undertaking</p>
MAY	<p>This word, or the adjective "OPTIONAL", means that an item is truly optional. One vendor may choose to include the item because a particular marketplace requires it or because the vendor feels that it enhances the product while another vendor may omit the same item.</p> <p>An implementation which does not include a particular option MUST be prepared to interoperate with another implementation which does include the option, though perhaps with reduced functionality. In the same vein an implementation which does include a particular option.</p> <p>MUST be prepared to interoperate with another implementation which does not include the option (except, of course, for the feature the option provides).</p>
Metadata	<p>Simply put, is data about data. It describes data, software services, and other components contained in the enterprise information systems. Examples of the types of metadata include standard data definitions, location and routing information, and synchronisation management for distributing shared data.</p>
MUST	<p>This word, or the terms "REQUIRED" or "SHALL", mean that the definition is an absolute requirement of the specification.</p>
MUST NOT	<p>This phrase, or the phrase "SHALL NOT", means that the definition is an absolute prohibition of the specification.</p>
NFS	<p>The Network File System (NFS) is a distributed file system protocol.</p>

Term	Description
	The Network File System (NFS) protocol provides transparent remote access to shared file systems across networks. The NFS protocol is designed to be machine, operating system, network architecture, and security mechanism, and transport protocol independent. This independence is achieved through the use of Remote Procedure Call (RPC) primitives built on top of an eXternal Data Representation (XDR).
Notified bodies	The bodies which are responsible for assessing the conformity or suitability for use of the interoperability constituents or for appraising the EC procedure for verification of the subsystems. (Directive 91/440/EC).
One Stop Shop (OSS)	An international partnership between rail Infrastructure Managers providing a single point of contact for rail customers for the purposes of: <ul style="list-style-type: none"> - Ordering specified train paths in international freight traffic, - Monitoring the entire train movement, - Generally also invoicing track access charges on behalf of IM's.
Open Access mode	Mode of train operation where only one RU is involved, which runs the train on various infrastructures. This RU contracts the needed paths with all involved IMs.
OSI	Open Systems Interconnection Describes a communication protocol of open systems based on the OSI reference model. Open systems are capable of communicating independent of proprietary solutions.
OSI reference model	Standard description of how messages should be transmitted between any two points in a network. The OSI model defines 7 layers of functions that take place at each end of a communication. These layers are the only internationally accepted framework of standards for communication.
OSS	One Stop Shop
Path	Path means the infrastructure capacity needed to run a train between two places over a given time-period (Route defined in time and space).
Path assembly	Joining up of individual train paths to extend path in terms of time and space.
Path number	Number of the defined train path
Peer-to-Peer	The term "peer-to-peer" refers to a class of systems and applications that employ distributed resources to perform a critical function in a decentralised manner. The resources

Term	Description
	encompass computing power, data (storage and content), network bandwidth, and presence (computers, human, and other resources). The critical function can be distributed computing, data/content sharing, communication and collaboration, or platform services. Decentralisation may apply to algorithms, data, and metadata, or to all of them. This does not preclude retaining centralisation in some parts of the systems and applications if it meets their requirements.
PKI	Public key infrastructure
Place of delivery	Place where the delivery happens (departure rail station to be given). a place where responsibility for the wagon is changed.
Place of departure	Place from which a means of transport is scheduled to depart or has departed.
Place of destination	Place at which the means of transport is due to arrive or has arrived. Synonym: Place of arrival
Pre-departure Period	is the delta time before the scheduled time of departure. The pre-departure period starts at scheduled time of departure minus delta time and ends at the scheduled time of departure.
Primary data	Basic data as reference data input for messages or as the basis for functionality and calculation of derived data.
Put into Service	A procedure dependent on the technical approval of a wagon and a contract for use with a RU which allows commercial operation of the wagon.
Railway Undertaking (RU)	Railway undertaking shall mean any public or private undertaking the principal business of which is to provide services for the transport of goods and/or passengers by rail with a requirement that the undertaking must ensure traction; this also includes undertakings which provide traction only.
RAMS	See Reliability, Availability, Maintainability, Safety.
RARP	Reverse Address Resolution Protocol (RARP)
Release date/time	Date/time when the goods are expected to be released or were released by the customer.
Release time for wagons	Date and time when the wagons are ready to be pulled from the named place on the customer siding.
Reliability, Availability, Maintainability, Safety (RAMS)	Reliability – The ability to start and continue to operate under designated operating conditions for a designated period expressed mathematically; Availability – The time in operation compared to the time out of service expressed mathematically;

Term	Description
	<p>Maintainability – The ability of a system to be put back into service after a failure expressed mathematically;</p> <p>Safety – The probability of a hazardous event being initiated by the system expressed mathematically.</p>
Reporting point	Location on the train journey, where the responsible IM has to issue a “train running forecast message” with TETA to the path contracted RU.
Repository	A repository is similar to a database and data dictionary, however it usually encompasses a comprehensive information management system environment. It must include not only descriptions of data structures (i.e. entities and elements), but also metadata of interest to the enterprise, data screens, reports, programs, and systems. Typically it includes and internal set of software tools, a DBMS, a metamodel, populated metadata, and loading and retrieval software for accessing repository data.
RID	Regulations concerning the international carriage of dangerous goods by rail.
RID number	OTIF number for dangerous goods
RIV	<p>Regulations governing the reciprocal use of wagons in international traffic.</p> <p>Regulations governing the reciprocal use of loading tackle, container and pallets in international traffic.</p>
Route	The geographical way to be taken from a starting point to a point of destination.
Route section	A part of a route
RPC	<p>Remote Procedure Call</p> <p>The RPC protocol is specified in the Remote Procedure Call Protocol Specification Version 2 [RFC1831].</p>
RU	See Railway undertaking
Scheduled time of departure	Date and Time of departure for which the path is requested.
Scheduled Timetable	Chronologically defined occupation of rail infrastructure for a train movement on open line or in stations. Changes to the timetables will be supplied by the IM s at least 2 days before the commencement of the day when the train departs from its origin. This timetable applies to a specific day. Known in some countries as the Operational Timetable.
Service Provider	Responsible carrier for this specific transport stage. Party who receives and handles the booking.

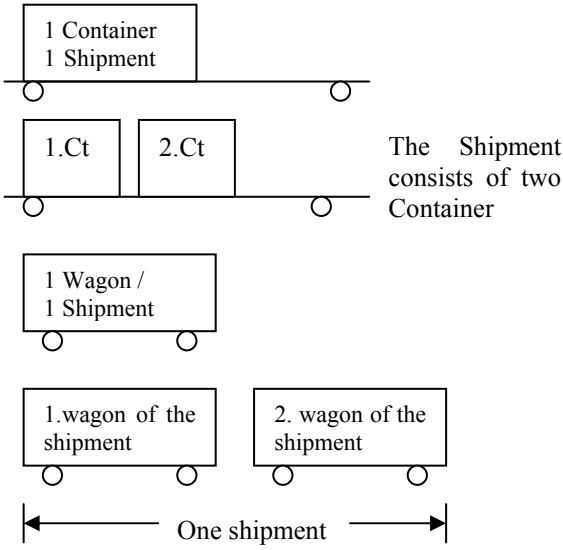
Term	Description
Shipment	<p>A package of goods from one consignor to one consignee, which is loaded in one or more complete IM units or which is loaded on one or more complete wagons.</p> <p>E;G;:</p>  <p>The diagram shows four examples of shipment units. The first is a box labeled '1 Container / 1 Shipment' on a single rail track. The second shows two boxes labeled '1. Ct' and '2. Ct' on a single rail track, with a note 'The Shipment consists of two Container'. The third is a box labeled '1 Wagon / 1 Shipment' on a single rail track. The fourth shows two boxes labeled '1. wagon of the shipment' and '2. wagon of the shipment' on separate rail tracks, with a double-headed arrow below them labeled 'One shipment'.</p>
Short notice path request	Individual request for a path according Directive 2001/14/EC Article 23 due to additional transport demands or operational needs.
SHOULD	This word, or the adjective "RECOMMENDED", mean that there may exist valid reasons in particular circumstances to ignore a particular item, but the full implications must be understood and carefully weighed before choosing a different course.
SHOULD NOT	This phrase, or the phrase "NOT RECOMMENDED" mean that there may exist valid reasons in particular circumstances when the particular behaviour is acceptable or even useful, but the full implications should be understood and the case carefully weighed before implementing any behaviour described with this label.
SMTP	Simple Mail Transfer Protocol
SNMP	Simple Network Management Protocol
SQL	<p>Structured Query Language</p> <p>A language devised by IBM, then standardised by ANSI and ISO, which is used for creating, managing and retrieving data in relational databases.</p>
Stakeholders	<p>Any person or organisation with a reasonable interest in train service delivery e.g.:</p> <p>Railway Undertaking (RU), Shipment monitoring provider, Locomotive provider,</p>

Term	Description
	<p>Wagon provider, Driver / Train crew provider, Hump yard provider, Switch move provider, Service integrator, Slot provider (IM), Train controller (IM), Traffic manager, Fleet manager Ferry boat provider, Wagon, locomotive inspector, Wagon, locomotive repair provider, Shipment manager, Switching & humping provider, Logistic provider, Consignee, Consignor, For Intermodal in addition:</p> <p>Container Provider, Intermodal terminal operator, Drayage provider / Haulage company, Steam ship, Barge lines.</p>
TCP	Transmission Control Protocol (TCP)
Technical Specification for Interoperability	means the specifications by which a subsystem or part subsystem is covered in order to meet the essential requirements and ensure the interoperability of the Trans-European conventional rail system.
TETA	See Train Estimated Time of Arrival
Tracing	Activity at request of finding and reconstructing the transport history of a given consignment, vehicle, equipment, package or cargo.
Tracking	Activity of systematically monitoring and recording the present location and status of a given consignment, vehicle, equipment, package or cargo.
Train Estimated Time of Arrival	Estimated Time of Arrival of a train at a specific point, e.g. handover point, interchange point, destination of the train.
Train path	Train route defined in time and space.
Train Path / Slot	A definition of a train's route in terms of time and the locations (marker points) at which it will originate and terminate along with details of those locations en-route at which it will either pass or call. The detail might also include any activities that the train will perform en-route for example train crew, locomotive or other consist changes.

Term	Description
Trans-European rail network	Rail network as described in Annex 1 to the Directive 2001/16/EC.
Transshipment	The operation of moving goods cargo items or unit loads from one vehicle to another or to and from storage.
Trip plan	For wagon or Intermodal unit shows the planned reference trip of the wagon / Intermodal unity.
TSI	See Technical Specification for Interoperability
Tunnelling	A process whereby private IP packets are encapsulated within a public IP packet.
UDP	<p>User Datagram Protocol</p> <p>Simple Traversal of User Datagram Protocol (UDP) through Network Address Translators (NATs) (STUN) is a lightweight protocol that allows applications to discover the presence and types of NATs and firewalls between them and the public Internet. It also provides the ability for applications to determine the public Internet Protocol (IP) addresses allocated to them by the NAT. STUN works with many existing NATs, and does not require any special behavior from them. As a result, it allows a wide variety of applications to work through existing NAT infrastructure.</p>
UIC	UIC is the international railway union.
UITP	UITP is the traffic operator's international co-operative organ.
UN number	United nation number for dangerous goods.
UNIFE	UNIFE is an organisation that takes care of the interests of the suppliers to the railway sector. Currently approximately 100 suppliers and subcontractors are directly represented and about 1000 indirectly through national organisations.
Unit capacity used	Code to indicate to which extent the equipment is loaded or empty. (e.g. full, empty, LCL).
Unit Load	A number of individual packages bonded, palletised or strapped together to form a single unit for more efficient handling by mechanical equipment.
Unit train	A freight train dispatched with only one consignment note and only one type of goods and composed of uniform wagons running from a consignor to a consignee without intermediate marshalling.
VPN	<p>Virtual Private Network</p> <p>The term Virtual Private Network has been used to describe almost any type of remote connectivity system, such as the public telephone network and Frame Relay PVC's.</p>

Term	Description
	<p>With the introduction of the Internet, VPN has become synonymous with remote IP-based data networking. Simply put, a VPN consists of two or more private networks that communicate securely over a public network.</p> <p>VPN can exist between an individual machine and a private network (client-to-server) or a remote LAN and a private network (server-to-server). The private networks are able to connect by tunnelling, A VPN commonly uses the Internet as an underlying transport network, but encrypts the data being sent between a VPN client and VPN gateway to ensure that it cannot be read even if intercepted in transit.</p>
Wagon load	A unit load whereas the unit is a wagon.
Wagon order	<p>A subset of the consignment note which shows the relevant information for a RU, needed to carry on the transportation during its responsibility until handover to a next RU.</p> <p>Instruction for the transportation of a wagon consignment.</p>
Waybill	The document made out by the carrier or on behalf of the carrier evidencing the contract for the transport of cargo.
Web	<p>World wide Web:</p> <p>An internet service that links documents by providing hypertext links from server to server so a user can jump from document to related document no matter where it is stored on the internet.</p>
XDR	<p>External Data Representation</p> <p>The XDR protocol is specified in External Data Representation Standard [RFC1832].</p> <p>XDR is a standard for the description and encoding of data. It is useful for transferring data between different computer architectures,. XDR fits into the ISO presentation layer, and is roughly analogous in purpose to X.409, ISO Abstract Syntax Notation. The major difference between these two is that XDR uses implicit typing, while X.409 uses explicit typing. XDR uses a language to describe data formats. The language can only be used only to describe data; it is not a programming language. This language allows one to describe intricate data formats in a concise manner. The alternative of using graphical representations (itself an informal language) quickly becomes incomprehensible when faced with complexity. The XDR language itself is similar to the C language. Protocols such as ONC RPC (Remote Procedure Call) and the NFS (Network File System) use XDR to describe the format of their data. The XDR standard makes the following assumption: that bytes (or octets) are portable, where a byte is defined to be 8 bits of data. A given hardware device should encode the bytes onto the various media in such a way that other hardware devices may decode the bytes without loss of</p>

Term	Description
	meaning.
XML-RPC	XML-RPC is an Extensible Mark-up Language-Remote Procedure Calling protocol that works over the Internet. It defines an XML format for messages that are transferred between clients and servers using HTTP. An XML-RPC message encodes either a procedure to be invoked by the server, along with the parameters to use in the invocation, or the result of an invocation. Procedure parameters and results can be scalars, numbers, strings, dates, etc.; they can also be complex record and list structures. This document specifies a how to use the Blocks Extensible Exchange Protocol (BEEP) to transfer messages encoded in the XML-RPC format between clients and servers.
XQL	Extended Structured Query Language

END OF DOCUMENT